

National Earthquake Hazards Reduction Program

... a research and implementation partnership for risk mitigation

Presentation for

ASCE
American Society of Civil Engineers

TCLEE 2009
CONFERENCE
JUNE 28—JULY 1, 2009
OAKLAND, CALIFORNIA



Lifeline Earthquake Engineering In a Multihazard Environment

1 July 2009

Jack Hayes – NEHRP Director

www.nehrp.gov

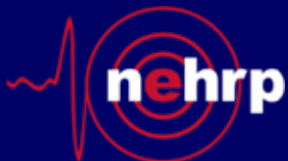

national **earthquake** hazards reduction program

Outline

- NEHRP Overview
- Quick NEHRP Update
- NEHRP Strategic Plan
- ACEHR Recommendation
- Snapshots of NEHRP Lifeline Activities

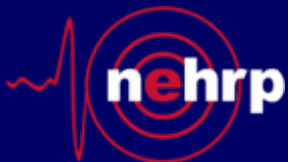

National Earthquake Hazards Reduction Program

A Statutory Multi-Agency Partnership

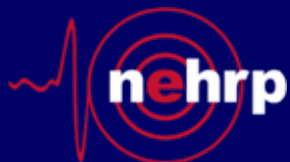

national **earthquake** hazards reduction program

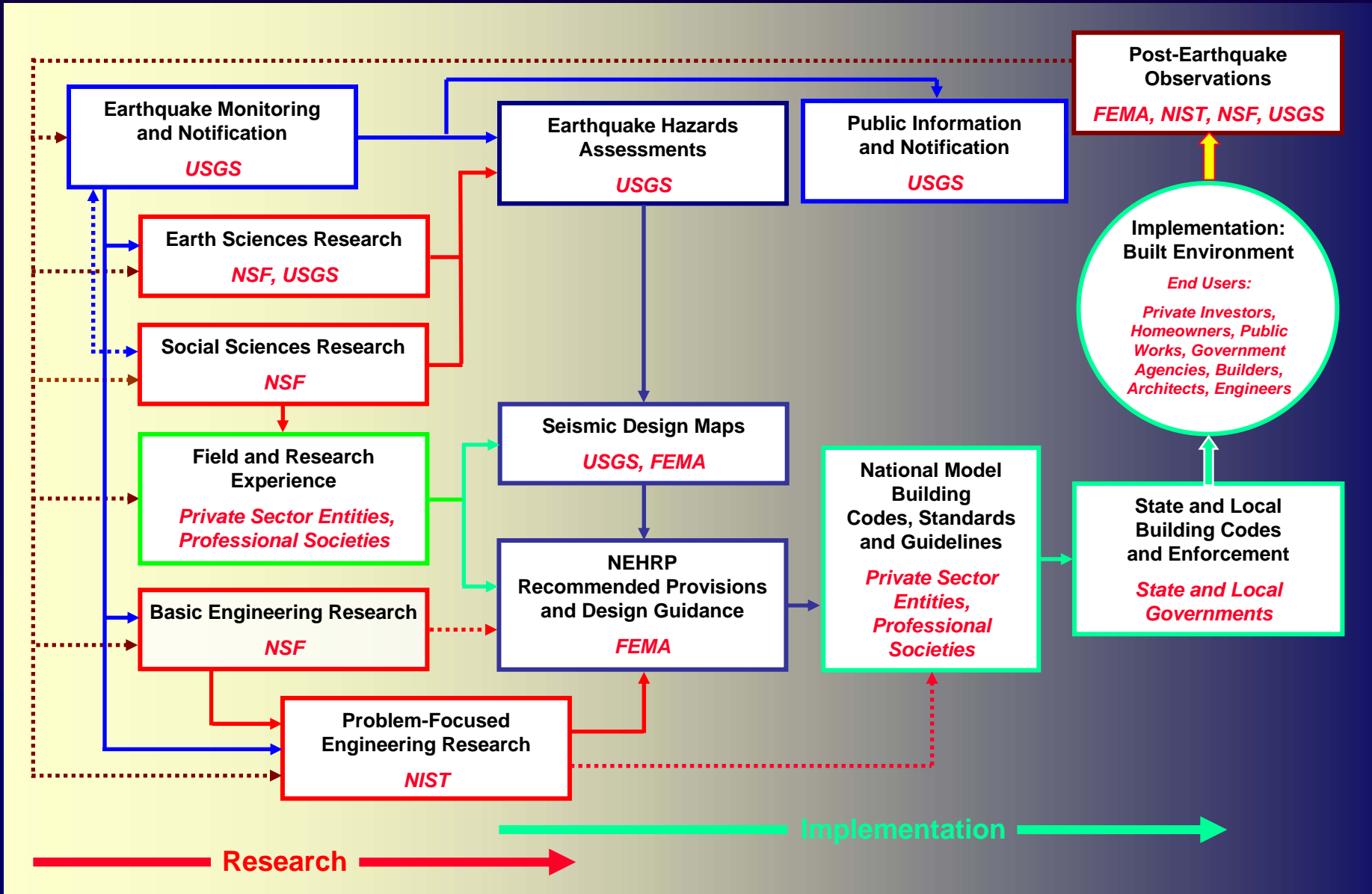

NEHRP Impact on the Built Environment

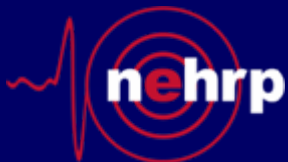

national earthquake hazards reduction program

Quick Update

- House and Senate are currently drafting new reauthorization legislation, to be effective in FY 2010.
 - Reauthorization hearings in House Science & Technology (S&T) Committee were held on 11 June 2009 - Link to hearing video is available at NEHRP web site.
 - House S&T Committee chair expressed interest in multi-hazard approaches in his comments.
- NEHRP has commissioned ongoing National Research Council study to develop a roadmap for future earthquake research activities.

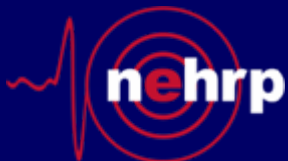

NEHRP Program Budgets

Agency	\$M											
	FY 2005		FY 2006		FY 2007		FY 2008		FY 2009		FY 2010	
	Authorized ¹	Enacted ²	Authorized ¹	Enacted ²	Authorized ¹	Enacted ²	Authorized ¹	Enacted ²	Authorized ¹	Enacted ²	Authorized ¹	Requested ³
FEMA ⁴	21.0	14.7	21.6	9.5	22.3	7.2	23.0	6.1	23.6	9.1	TBD	9.1
NIST ⁵	10.0	0.9	11.0	0.9	12.1	1.7	13.3	1.7	14.6	4.1	TBD	4.1
NSF ⁶	58.0	53.1	59.5	53.8	61.2	54.2	62.9	55.6	64.7	55.3	TBD	57.0
USGS ⁷	77.0	58.4	84.4	54.5	85.9	55.4	87.4	58.1	88.9	61.2	TBD	61.5
Totals	166.0	127.1	176.5	118.7	181.5	118.5	186.6	121.5	191.8	129.7	TBD	131.7

Notes:

- Budgets through FY 2009 authorized by Congress in Public Law 108-360. FY 2010 budgets to be determined in new authorization.
- “Enacted” budgets reported by NEHRP agencies for FY 2005 – FY 2009.
- “Requested” budgets for NEHRP agencies in President’s FY 2010 Budget Request, except for FEMA.
FEMA FY 2010 “requested” budget is estimated portion of President’s FY 2010 DHS budget request that will be allocated for FEMA NEHRP activities.
- FEMA FY 2005 enacted budget covered program activities and S&E, but excluded state grants.
FEMA FY 2006 – FY 2009 enacted budgets covered program activities, but excluded S&E and state grants.
- NIST budgets support NEHRP Secretariat and NIST Earthquake Risk Mitigation R&D Program.
- NSF budgets include NEES O&M funds: FY 2005 -\$17.9M, FY 2006 - \$20.3M, FY 2007 - \$20.5M, FY 2008 - \$22.1M, FY 2009 - \$20.8M, FY 2010 - \$23.9M.
- USGS authorization includes for ANSS: FY 2005 - \$30M, FY 2006 and beyond - \$36M per year.
USGS FY 2005 enacted budget includes funds for tsunami warning from emergency supplemental appropriation (\$3.95M for EHP, \$4.15M for GSN).
USGS budgets include GSN funds: FY 2005 - \$7.5M, FY 2006 - \$3.9M, FY 2007 - \$3.9M, FY 2008 - \$4.4M, FY 2009 - \$5.5M, FY 2010 - \$5.5M.



Strategic Plan

Outline

- Executive Summary
- Introduction – Background (History, Prior Accomplishments)
- Vision / Mission / Strategic Planning Principles
- Goals / Objectives / Outcomes
- Strategic Priorities
- Summary
- Appendices

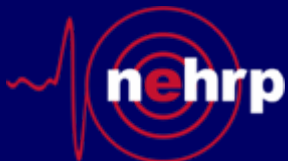
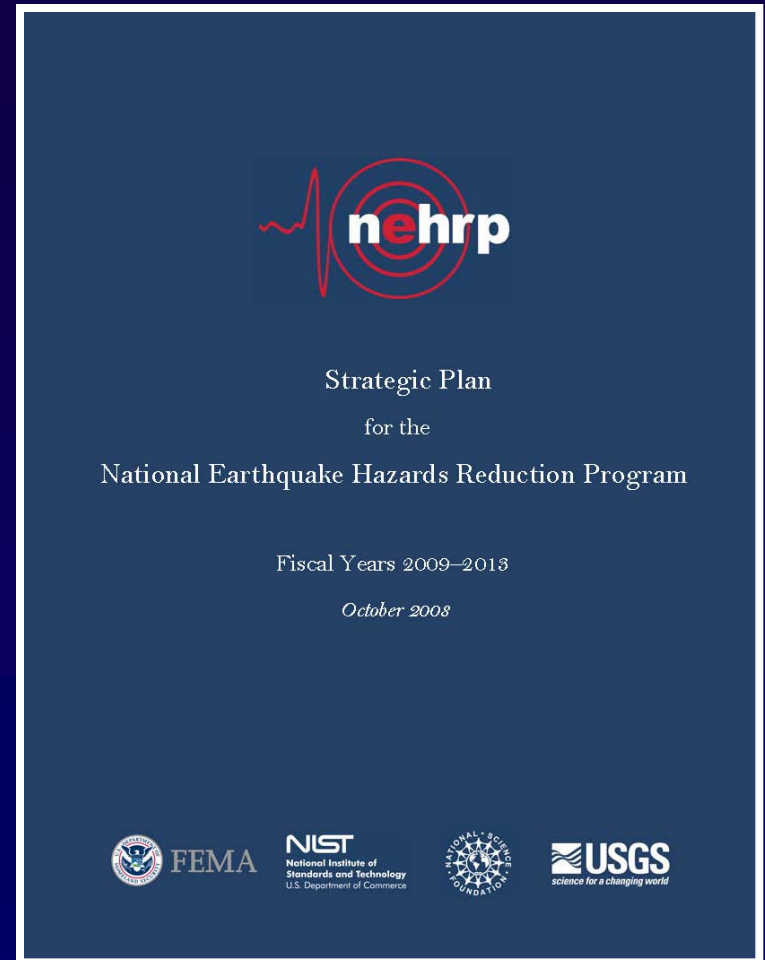

NEHRP Strategic Plan

National Vision Statement

The Program is driven by a national vision for the future:

*A nation that is earthquake-resilient
in public safety, economic strength, and
national security.*

This vision gives rise to the NEHRP Mission Statement (see next slide).

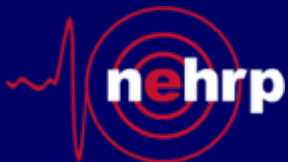

national **earthquake** hazards reduction program

NEHRP Mission Statement

To develop, disseminate, and promote knowledge, tools, and practices for earthquake risk reduction – through coordinated, multi-disciplinary partnerships among the NEHRP agencies and their stakeholders – that improve the nation’s earthquake resilience in public safety, economic strength and national security.

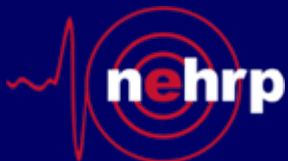

Strategic Goals

- A. Improve understanding of earthquake processes and impacts.
- B. Develop cost-effective measures to reduce earthquake impacts on individuals, the built environment, and society-at-large.
- C. Improve the earthquake resilience of communities nationwide.

Goals closely parallel three major statutory program activities.

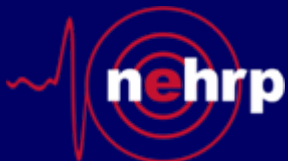

Strategic Planning Principles

... *including* ...

- Program impact through effective development and transfer of knowledge, tools, and practices
- Program revision – not reinvention
- Interagency coordination / cooperation / synergy
 - Includes coordinated budget development
 - Emphasizes that progress towards all Plan goals and objectives presented in this Plan will be made, but not all of the outcomes will be fully realized during the Plan period of 2008 – 2012
- Adoption of **nine Strategic Priorities** that support Program goals and objectives



Strategic Planning Principles (cont'd)

- Close partnerships with stakeholder communities
- Exploitation of ANSS, GSN, NEES
 - Includes emphasis on instrumentation and facility utilization by program
 - Includes recurring support for operating key research and data collection facilities (e.g. ANSS, NEES), providing the necessary foundation for achieving Plan goals and objectives
- Multi-disciplinary approach
- Multi-hazard leveraging awareness
- Linkages with broader federal policies, plans, and priorities (e.g. SDR *Grand Challenges for Disaster Reduction*)
- Increased international cooperation

Strategic Plan Structure

- NEHRP goals:

Broad and long-term with expected impacts that should be realized, in full or in part, during the five year planning period; serve to guide and focus NEHRP planning and activities to accomplish the NEHRP Mission.

- NEHRP objectives:

Specific achievements towards broad goals, with expected outputs and outcomes, that should be realized, in full or in part, during the five year planning period.

Note:

Fulfilling many of the objectives will contribute to more than one goal.
Objectives are listed under the goal to which they principally contribute.

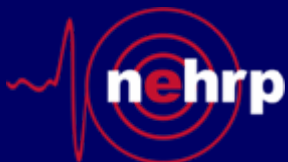

Goal A: Improve understanding of earthquake processes and impacts

- Objective 1: Advance understanding of **earthquake phenomena and generation processes**
- Objective 2: Advance understanding of **earthquake effects** on the built environment
- Objective 3: Advance understanding of **social, psychological, and economic factors** linked to implementing risk reduction and mitigation strategies in the public and private sectors
- Objective 4: Improve **post-earthquake information management**

Goal B: Develop cost-effective measures to reduce earthquake impacts on individuals, the built environment, and society at large.

- Objective 5: **Assess earthquake hazards** for research and practical application
- Objective 6: Develop **advanced loss estimation and risk assessment tools**
- Objective 7: Develop tools to improve the seismic performance of **buildings and other structures**
- Objective 8: Develop tools to improve the seismic performance of **critical infrastructure**

Goal C: Improve the earthquake resilience of communities nationwide

- Objective 9: Improve the accuracy, timeliness, and content of **earthquake information products**
- Objective 10: Develop comprehensive **earthquake scenarios and risk assessments**
- Objective 11: Support development of **seismic standards and building codes** and advocate their adoption and enforcement

Goal C: Improve the earthquake resilience of communities nationwide (continued)

- Objective 12: **Promote the implementation** of earthquake-resilient measures in professional practice and in private and public policies
- Objective 13: Increase **public awareness** of earthquake hazards and risks
- Objective 14: Develop the nation's **human resource base** in earthquake safety fields

Strategic Priorities

Describes 2006 ICC examination of “gaps” & emphasizes 9 strategic priorities (presented in order of first association with goals and objectives):

- Fully implement **Advanced National Seismic System (ANSS)**
- Improve techniques for evaluating & rehabilitating **existing buildings**
- Further develop **Performance-Based Seismic Design (PBSD)**
- Increase consideration of **socio-economic issues** related to hazard mitigation implementation

Strategic Priorities (continued)

Describes 2006 ICC examination of “gaps” & emphasizes 9 strategic priorities (presented in order of first association with goals and objectives):

- Develop a **Post-Earthquake Information Management System (PIMS)**
- Develop **advanced risk mitigation technologies & practices**
- Develop earthquake-resilient **lifeline** components and systems
- Develop & conduct earthquake **scenarios** for effective earthquake risk mitigation
- Facilitate improved earthquake mitigation at **state & local** levels

2009 ACEHR Recommendation

4 May 2009 letter to NIST Deputy Director Pat Gallagher from **Advisory Committee on Earthquake Hazards Reduction**:

“Enhance collaboration and advancements in lifeline engineering.”

- NEHRP agencies need to expand efforts.
- Central oversight is needed.
- Professional community expertise should be tapped.
- Regulatory oversight is needed.

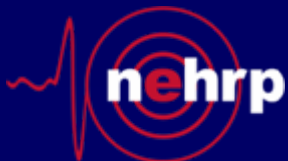

Great Southern California Shakeout: Cajon Pass



The circled points at Cajon Pass, I-10 & Rt. 14 were the subject of special studies included in the ShakeOut report: white – power; yellow – fuel; light blue – telecomm; orange – transport; black - rail



Cajon Pass

Co-located Lifelines at the San Andreas Fault Crossing

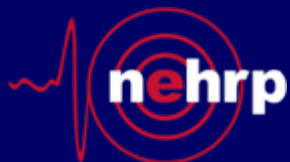
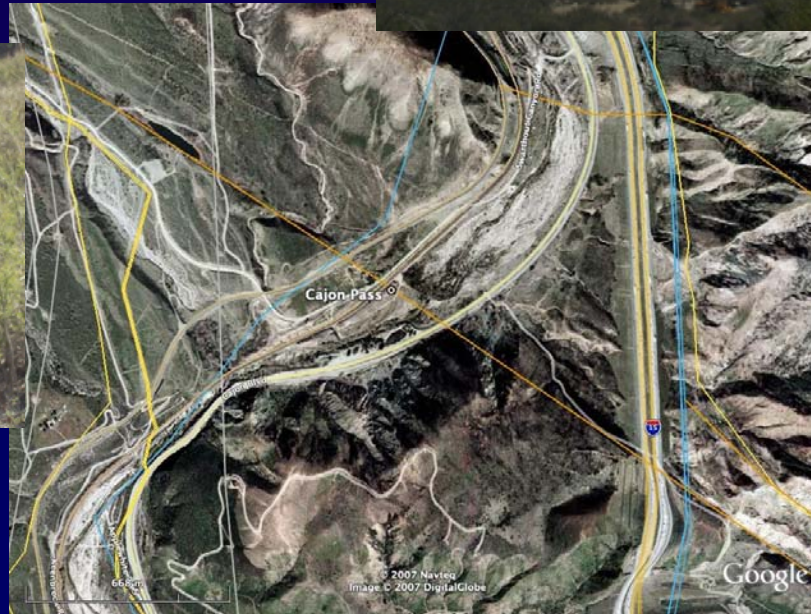

Courtesy USGS

national earthquake hazards reduction program

Policy Points – IECLA'08

“Long-term economic impact is strongly influenced by efficient restoration of lifelines, so retrofit of all essential pipelines (especially those co-located which create extreme vulnerability) should be required to (sic) current standards.”

“A plan to deal with potential large scale disruptions of critical lifeline infrastructure is essential to ensure public safety, efficient emergency response and repairs. To assist in planning, a thorough assessment of the seismic and surface faulting threat to existing critical lifelines is required.”

International Earthquake Conference, Los Angeles 2008

John Bwarie, staff of Los Angeles Council Member Greig Smith

Courtesy USGS

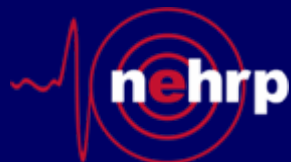



Seismic Risk Management for Port Systems

SAFEGUARDING THE INFRASTRUCTURE OF GLOBAL TRADE
www.neesgc.gatech.edu

NSF Award 0530478



NIST has initiated project with NEHRP Consultants Joint Venture to facilitate transition of NEES project results into appropriate standards/guidelines.



Tests on pile-deck connections at UW



Centrifuge tests on liquefaction mitigation methods at UC Davis



Port of Kobe

Images courtesy of Dr. Glenn Rix, Ga Tech

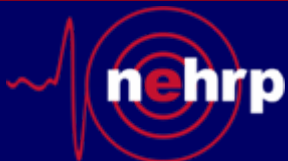

Seismic Performance of Bridge Systems with Conventional and Innovative Materials

NSF Award CMMI-0420347

University of Nevada



NEES triple biaxial shake tables at University of Nevada, Reno



Bridge bents designed with novel materials, e.g., shape memory alloy reinforcement, elastomeric pads, and polyvinyl fiber concrete, could revolutionize seismic design of bridges.

Graphics: Professor M. Saïdi, University of Nevada, Reno



Conventional Design



Conventional Design



SMA Bent

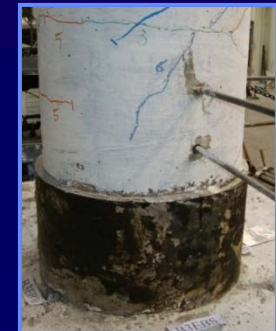

Elasto Bent

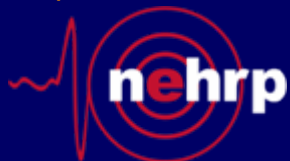

Understanding Seismic Performance of Utility Lifelines (NSF Award CMMI-0421142) Cornell University

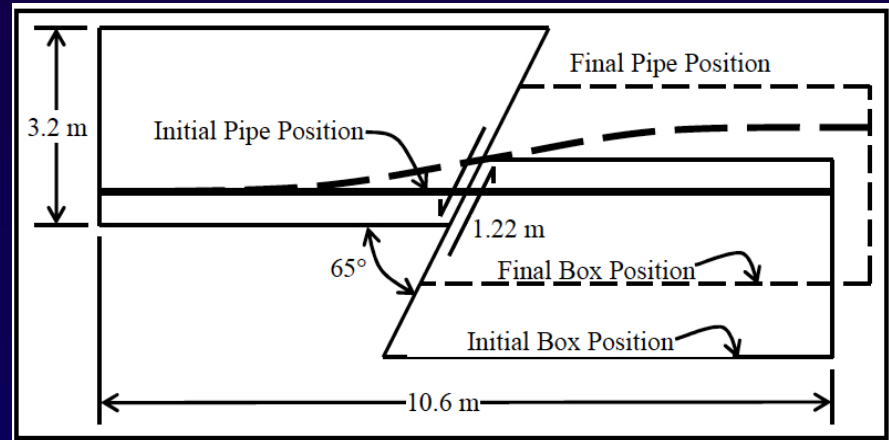
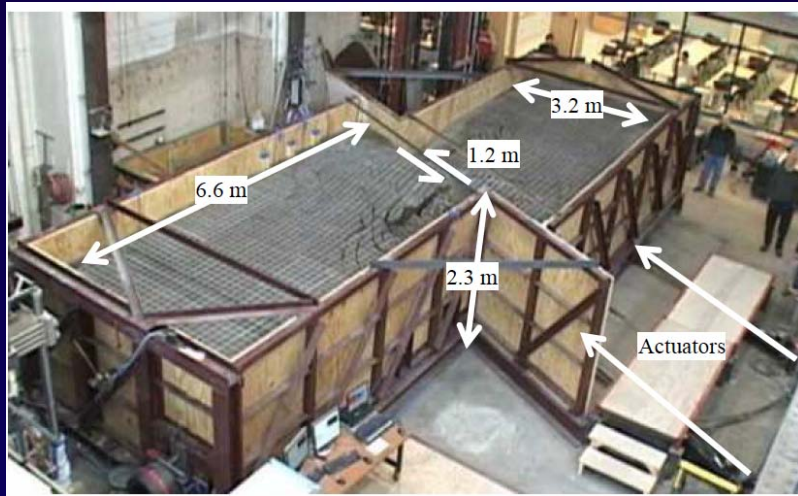

Understanding complex deformation patterns in underground utility pipelines subjected to fault rupture. High-density polyethylene (HDPE) has high ductility preventing pipeline rupture during strains induced by ground movement.

Graphics from nees.cornell.edu

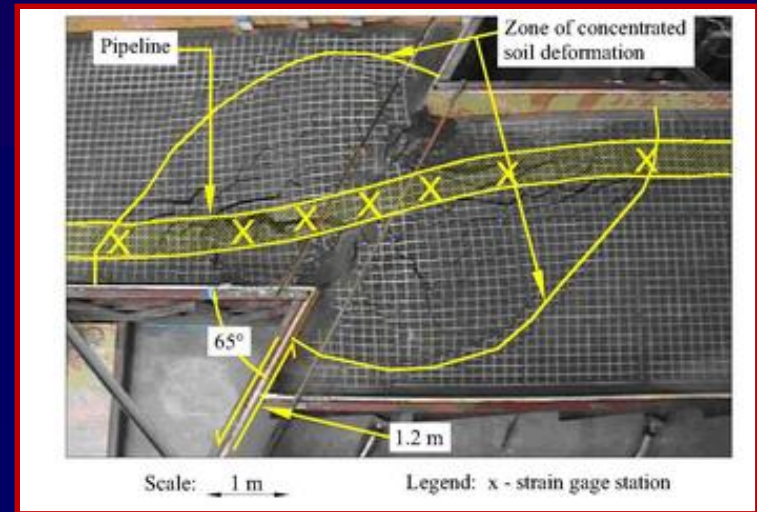

Multi-site Hybrid Testing Distributed Bridge Testing using NEES Equipment at UIUC, RPI, and Lehigh

Multi-Site Soil-Structure-Foundation Interaction Test (MISST)
NSF "Pre-NEESR" Awards 0406812 (UIUC) and 0407555 (Lehigh)

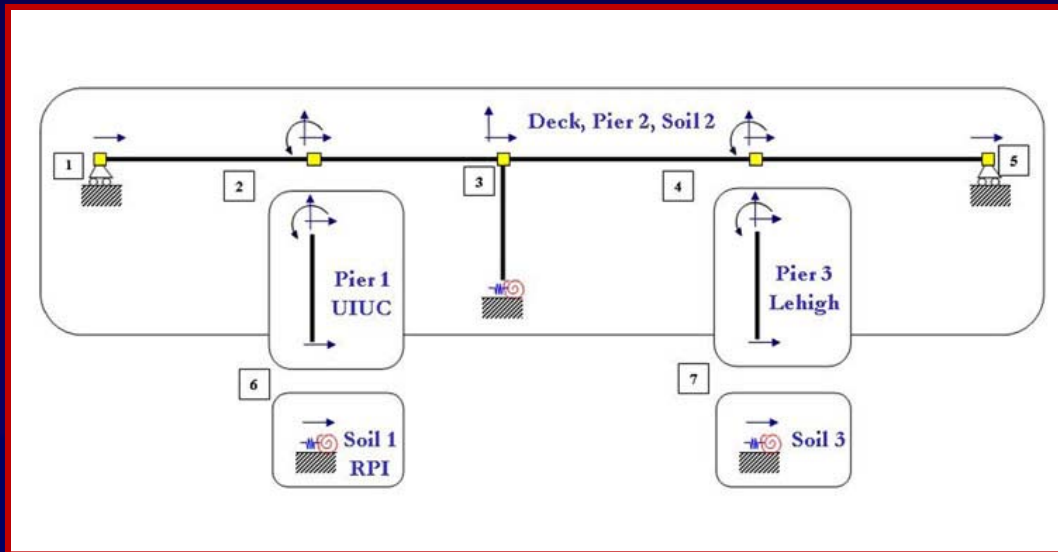

Substructuring

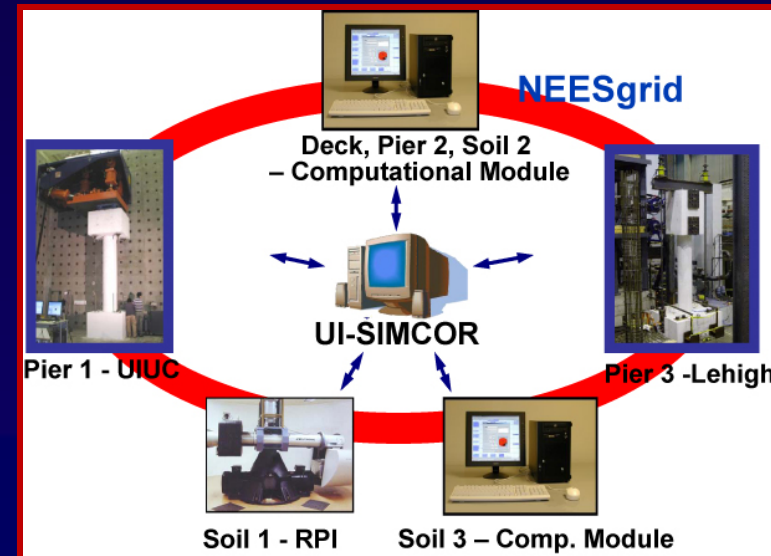

Distributed Hybrid Simulation Test

Graphics courtesy of Amr Elnashai (UIUC)

Reference: http://cee-nees.cee.uiuc.edu/research/MISST_Report_Final_Web.pdf

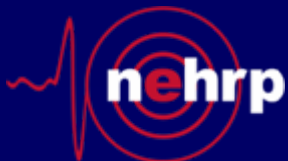

AmericanLifelinesAlliance

A Public-private Partnership to Reduce Risk to Utility and Transportation Systems from Hazards

www.americanolifelinesalliance.org

ALA was created as a partnership among FEMA, ASCE, FHWA, USGS, BOR, PG&E, Rohn Industries, Pima County, AZ Wastewater Management, Baker Engineering, and SEAoNY.

The web site is still active and has several documents available for download.

ALA is now in a hiatus status, pending future FEMA initiatives.

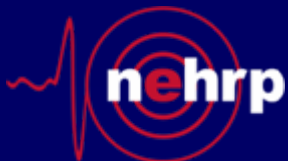

national **earthquake** hazards reduction program

ALA-Recommended Future Projects

Lifeline	Guideline
Aboveground Steel Tanks	Seismic Design
Utility and Transportation Lifeline Systems	System Reliability for All Hazards
Electric Power Transmission Towers and Distribution Poles	Natural and Man-Made Hazards Design
Wastewater Systems	Natural and Man-Made Hazards Design
Oil and Natural Gas Pipeline Systems	Natural and Man-Made Hazards Design