

2011

AMERICAN SOCIETY OF CIVIL ENGINEERS®
NATIONAL CONCRETE CANOE COMPETITION™

RULES AND REGULATIONS



ASCE
AMERICAN SOCIETY OF CIVIL ENGINEERS

TABLE OF CONTENTS

INTRODUCTION.....	ii
AWARDS AND RECOGNITION.....	iii
ASCE NATIONAL CONCRETE CANOE COMPETITION™ SPONSORS	iv
PAST WINNERS AND HOST SCHOOLS.....	v
ASCE CORPORATE PROFILE	vii
R. JOHN CRAIG MEMORIAL AWARD	viii
Section 1 – GENERAL RULES AND ELIGIBILITY REQUIREMENTS	1
Section 2 – CANOE	6
Section 3 – CONCRETE	12
Section 4 – REINFORCEMENT	18
Section 5 – FINISHING	21
Section 6 – DESIGN PAPER	23
Section 7 – ENGINEER’S NOTEBOOK	29
Section 8 – ORAL PRESENTATION.....	32
Section 9 – FINAL PRODUCT (Canoe and Cutaway Section).....	33
Section 10 – PRODUCT DISPLAY	36
Section 11 – RACE RULES AND REGULATIONS	37
Section 12 – NATIONAL QUALIFYING RULES	43
Section 13 – OVERALL SCORING	44
Appendix A – Judges’ Score Sheets	
Design Paper Score Sheet	A-1
Oral Presentation Score Sheet	A-2
Final Product Aesthetics Score Card.....	A-3
Instructions - Deduction Score Cards	A-4
Design Paper Deduction Score Card.....	A-5
Final Product Deduction Score Card	A-6
Appendix B – Forms	
Repair Procedure Report.....	B-1
Reconstruction Request	B-2
Damage/Accident Report	B-3
Request for Clarification and Appeals Form (Conference Competition)	B-4
Request for Clarification and Appeals Form (National Competition).....	B-5
Appendix C – General Guidelines for Concrete Mixture Data Table 3.1	C-1
Appendix D – Formatting of Electronic Deliverables	D-1

INTRODUCTION

ASCE Student Organizations have been involved in constructing and racing concrete canoes on the local and regional (now conference) level since the early 1970's. The first National Competition came to fruition in the summer of 1988 after almost two years of discussion between representatives from the American Society of Civil Engineers (ASCE) and Master Builders, Inc.

The objectives of the National Competition are as follows:

- To provide civil engineering students an opportunity to gain hands-on, practical experience and leadership skills by working with concrete mix designs and project management.
- To increase awareness of the value and benefits of ASCE membership among civil engineering students and faculty in order to foster lifelong membership and participation in the Society.
- To build awareness of the versatility and durability of concrete as a construction material among civil engineering students, educators and practitioners, as well as the general public.
- To build awareness of concrete technology and application among civil engineering students, educators and practitioners, as well as the general concrete industry.
- To increase awareness among industry leaders, opinion makers and the general public of civil engineering as a dynamic and innovative profession essential to society.
- To generate and increase awareness of ASCE's and national sponsors' commitment to civil engineering education among civil engineering students, educators and practitioners, as well as the general public.

While the intent of the competition is to learn and to create a forum for interaction both technically and socially, the students are a short step from being practicing engineers involved in projects that are critical to society's welfare. Hence, we shall expect professional conduct from all participants. In order to preserve the quality of this competition and to improve the quality of future competitions, we shall demand high standards, which shall be enforced under the Section 1.8, "Spirit of the Competition."

The rules are divided into thirteen (13) sections plus several appendices; please review each section thoroughly.

Good luck, have fun and be safe! May the best team win!

AWARDS AND RECOGNITION

The winners of the National Concrete Canoe Competition™ shall be determined by compiling a team's total number of points from the academic and race portions of the competition. ASCE shall award a total of \$9,000 in academic scholarships to the winning teams' undergraduate civil engineering program. To be eligible to receive a scholarship, the entrant school must be a recognized ASCE Student Organization.

The local ASCE Student Chapter shall determine selection of the academic scholarship winner(s). The academic scholarships shall be awarded to student member(s) within twelve (12) months of completion of the current years' national finals. The academic scholarship money shall be used toward satisfying tuition reimbursements only and shall not be used to fund current or future concrete canoe competitions. ASCE shall be notified in writing of academic scholarship winner(s) prior to distribution to recipients.

Total scholarship awards shall be distributed as follows:

1st place overall winner:	\$5,000 scholarship and trophy
2nd place overall winner:	\$2,500 scholarship and trophy
3rd place overall winner:	\$1,500 scholarship and trophy

Special plaques shall be awarded to the top team in the following individual categories:

4th place overall winner:	Commemorative Plaque
5th place overall winner:	Commemorative Plaque
Best Design Paper	Women's slalom/endurance race
Best Oral Presentation	Men's slalom/endurance race
Best Final Product	Women's sprint race
Spirit of the Competition	Men's sprint race

A special plaque in honor of R. John Craig, a former ASCE Committee on Student Services member who was a driving force behind the National Concrete Canoe Competition, shall be awarded to the team that has the best time in the coed race.

Appropriate awards shall be presented to teams finishing second through fifth in each event. Each team shall receive a commemorative plaque for their participation in the National Concrete Canoe Competition™. All ten (10) registered team members in the National Concrete Canoe Competition™ shall receive a certificate of participation for the National Competition.

ASCE NATIONAL CONCRETE CANOE COMPETITION™ SPONSORS

**THANK
YOU**

ASCE thanks the National Concrete Canoe Competition sponsors for their support in making the event possible.

If you are interested in becoming a sponsor of the 2011 ASCE National Concrete Canoe Competition™, please contact Loretta Cranbourne at 703.295.6288 or lcranbourne@asce.org.

PAST WINNERS AND HOST SCHOOLS

2010 (California Polytechnic State University San Luis Obispo, San Luis Obispo, CA)

1. California Polytechnic State University San Luis Obispo
2. University of Nevada, Reno
3. École de technologie supérieure
4. Michigan Technological University
5. University of Wisconsin – Madison

2009 (University of Alabama, Tuscaloosa, AL)

1. University of California – Berkeley
2. École de technologie supérieure
3. California Polytechnic State University San Luis Obispo
4. University of Florida
5. University of Nevada – Reno

2008 (École de technologie supérieure, Montréal, QC)

1. University of Nevada – Reno
2. University of California – Berkeley
3. École de technologie supérieure
4. California Polytechnic State University San Luis Obispo
5. University of Florida

2007 (University of Washington, Seattle, WA)

1. University of Wisconsin – Madison
2. University of Florida
3. University of Nevada – Reno
4. Western Kentucky University
5. California Polytechnic State University San Luis Obispo

2006 (Oklahoma State University, Stillwater, OK)

1. University of Wisconsin – Madison
2. California Polytechnic State University San Luis Obispo
3. Clemson University
4. University of California – Berkeley
5. Michigan Technological University

2005 (Clemson University, Clemson, SC)

1. University of Wisconsin – Madison
2. Clemson University
3. Michigan Technological University
4. University of California – Berkeley
5. United States Military Academy (West Point)

2004 (ASCE & Catholic University, Washington, DC)

1. University of Wisconsin – Madison
2. Université Laval
3. University of Alabama in Huntsville
4. Clemson University
5. Milwaukee School of Engineering

2003 (Drexel University, Philadelphia, PA)

1. University of Wisconsin – Madison
2. Université Laval
3. University of California – Berkeley
4. Clemson University
5. University of Oklahoma

2002 (University of Wisconsin – Madison, Madison, WI)

1. Clemson University
2. Université Laval
3. Oklahoma State University
4. Western Kentucky University
5. University of Wisconsin – Madison

2001 (San Diego State University, San Diego, CA)

1. University of Alabama in Huntsville
2. Clemson University
3. Oklahoma State University
4. Université Laval
5. South Dakota School of Mines and Technology

2000 (Colorado School of Mines, Golden, CO)

1. Clemson University
2. Oklahoma State University
3. Florida Institute of Technology
4. Michigan State University
5. University of Washington

- 1999 (Florida Institute of Technology, Melbourne, FL)
1. Clemson University
 2. University of Alabama in Huntsville
 3. Oklahoma State University
 4. University of Washington
 5. South Dakota School of Mines and Technology
- 1998 (South Dakota School of Mines and Technology, Rapid City, SD)
1. University of Alabama in Huntsville
 2. California State University at Sacramento
 3. Clemson University
 4. Florida Institute of Technology
 5. University of Washington
- 1997 (Cleveland State University, Cleveland, OH)
1. Florida Institute of Technology
 2. University of Alabama in Huntsville
 3. University of California – Berkeley
 4. Michigan State University
 5. University of California – Los Angeles
- 1996 (University of Wisconsin – Madison, Madison, WI)
1. University of Alabama in Huntsville
 2. Michigan State University
 3. University of California – Berkeley
 4. South Dakota School of Mines and Technology
 5. Clemson University
- 1995 (George Washington University, Washington, DC)
1. South Dakota School of Mines
 2. California State University at Sacramento
 3. Michigan State University
 4. Clemson University
 5. University of New Orleans
- 1994 (University of New Orleans, New Orleans, LA)
1. University of Alabama in Huntsville
 2. University of California – Berkeley
 3. University of New Orleans
 4. South Dakota School of Mines and Technology
 5. Clemson University
- 1993 (California State University – Sacramento, Sacramento, CA)
1. University of Alabama in Huntsville
 2. Michigan State University
 3. University of California – Berkeley
 4. University of New Orleans
 5. Colorado State University
- 1992 (Colorado State University, Fort Collins, CO)
1. University of California – Berkeley
 2. University of Alabama in Huntsville
 3. University of New Orleans
 4. University of Maryland
 5. Michigan State University
- 1991 (University of Central Florida, Orlando, FL)
1. University of California – Berkeley
 2. University of Maryland
 3. State University of New York – Buffalo
 4. University of Illinois – Urbana/Champaign
 5. University of Texas – Austin
- 1990 (State University of New York – Buffalo, Buffalo, NY)
1. Michigan State University
 2. University of Maryland
 3. University of California – Berkeley
 4. University of Texas – Austin
 5. University of Wisconsin – Milwaukee

CORPORATE PROFILE

American Society of Civil Engineers (ASCE)

The American Society of Civil Engineers (ASCE) is the oldest national engineering society in the United States. Founded in 1852 with 12 members, the Society was created to disseminate information among engineers who were building the roads, canals, bridges and railroads of a young nation.

Today, ASCE has more than 144,000 members, including some 14,000 of whom are international members residing outside the United States in 167 countries. Individual professional engineers rather than companies or organizations hold membership. The members are organized geographically into ten regions, 87 sections, 158 branches and 281 student chapters and international student groups.

The objective of ASCE is to enhance the welfare of mankind through the advancement of the science and profession of engineering. In response to these goals, more than 6,000 members voluntarily serve nearly 600 different technical, administrative and coordinating committees. Another 300 participate on 36 other professional committees. Including the activities of sections, student chapters and international student groups, as well as the national and local committees, ASCE groups average 100 meetings throughout the country every day.

Educational activities extend to college campuses through 281 student organizations. These organizations sponsor meetings; educational outreach, conferences, student competitions, social events and other activities to help future engineers become better prepared for their careers. Numerous scholarships and awards are made available for deserving students of civil engineering.

A 17-member Board of Direction governs the Society. The Board, which includes ASCE officers and representatives elected by the membership, establishes all policy for the organization. A staff of 250 implements the policies; the vast majority of staff work at ASCE International Headquarters located in Reston, Virginia.

For more information, visit <http://www.asce.org>.



R. JOHN CRAIG MEMORIAL AWARD

The concept of a National Concrete Canoe Competition™ had been around for a number of years. In the mid 1980s Dr. R. John Craig, a professor at the New Jersey Institute of Technology and member of the ASCE Committee on Student Services (CSS), and other members of CSS began to formulate plans for more uniform Regional Competitions and formalized a plan to study the feasibility of a National Competition.

In the spring of 1985 Dr. Craig first brought his grand vision of a National Concrete Canoe Competition™ to ASCE. He was instrumental in bringing delegates from all over the country to meet one auspicious day in New York City at the executive conference of the ASCE National Headquarters. During this meeting the feasibility of conducting a National Concrete Canoe Competition™ was discussed, preliminary rules prepared, and a formal recommendation to proceed was drafted.

In the fall of 1985 the preliminary rules were presented to the Committee on Student Services (CSS). During the next year discussions regarding sponsorship were conducted with Master Builders, Inc. and ASCE Headquarters. After almost two years of committee debate, while meeting at the fall 1987 ASCE National Convention the Educational Activities Committee (EdAC) adopted the preliminary rules and established a standing task committee to implement the rules and requirements.

In the winter of 1987, just as the first National Competition was in sight, Dr. Craig was diagnosed with a rare inoperable brain tumor. He passed away just two months before his dream of a National Concrete Canoe Competition came to fruition. In June of 1988 the first National Competition was held in East Lansing, Michigan hosted by Michigan State University.

In the spring of 1989, CSS approved the formation of a permanent subcommittee to ensure the execution of the National Concrete Canoe Competition. Through the efforts and dedication of individuals like Dr. R. John Craig their efforts have established this National Concrete Canoe Competition™.

In that spirit ASCE has dedicated the Coed Sprint Race as a memorial to the teamwork and dedication of Dr. R. John Craig. It is our distinct honor to present the *R. John Craig Memorial Award* to the school that best exemplifies the spirit and cooperative ideals of the Competition by placing first in the Coed Sprint Race each year.

Section 1 – GENERAL RULES AND ELIGIBILITY REQUIREMENTS

1.0 RULE CHANGES AND PRECEDENCE

The Rules and Regulations (Rules) of the National Concrete Canoe Competition™ (NCCC or National Competition) are updated each year in an effort to improve the overall competition. **Teams are strongly cautioned to read this entire document carefully and disregard rules and website postings from previous years.** Teams should not consider items such as, but not limited to, previous rulings and interpretations made by conference and national judges and answers provided in previous *Frequently Asked Questions* (FAQ) as setting precedence for this year's competition.

1.1 QUALIFIERS

A team shall have qualified as a first place winner or designated alternate in conjunction with one of the eighteen (18) ASCE Student Conferences or as the host school of the National Competition. All qualifying teams and the host school must represent an ASCE Student Organization. The host school has the choice of competing in the current year or delaying their entry until the following year. The host school must compete at the conference competition during the same year it intends on competing in the National Competition.

To facilitate broader participation by ASCE Student Organizations in Student Conference activities, the ASCE Committee on Student Activities (CSA) stresses the importance of the conference as an event that is much more than a qualifying round for national competitions and highlights the required events at a conference. As such, the following qualifications are required of all ASCE Student Organizations in order to participate in an ASCE-sponsored National Competition.

An ASCE Student Organization must:

1. Be in good standing with ASCE (annual report and annual dues submitted and received by ASCE prior to the start of the Student Conference).
2. Attend and participate in their assigned Student Conference as shown through their school's:
 - a) Good faith participation in the Student Conference Business Meeting (i.e. on time attendance by at least one student representative);
 - b) Good faith participation in the Student Conference Paper Competition (i.e. submission and presentation by at least one (1) member of the ASCE Student Organization); and
 - c) Meeting any additional requirements of Student Conference participation set by the Student Conference at the previous year's business meeting or in their written and approved, by-laws, standing rules, or constitution.

Notes: The concrete canoe design paper/oral presentation does not count as an entry into the Student Conference Paper Competition. It is not a requirement that a concrete canoe (or steel bridge) team member submit and present a Student Conference Paper.

In order to earn an invitation to the National Competition a student team shall qualify through participation in its assigned ASCE Conference Concrete Canoe Competition (Conference Competition). There must be at least three (3) eligible ASCE Student Organizations that are official members of the Conference participating in the concrete canoe competition in order to constitute a qualified Conference Competition. In addition, a Conference

Competition must be hosted by a school that is an official member of the Conference. Only one (1) team from any given university can compete in a Conference Competition.

If any of the top five placed teams from the previous year's National Competition (see PAST WINNERS AND HOST SCHOOLS) qualify for the current year's National Competition, the second place team from their respective conference will be invited to attend the National Competition, assuming that they meet all of the qualification requirements. This applies to any two teams from the same conference that may placed in the top five at the previous year's National Competition and then finish first-second in the following years' Conference Competition (e.g., the third place team is not invited to the National Competition).

1.2 REGISTERED PARTICIPANTS

A team may register up to a maximum of five (5) male and five (5) female participants. Teams may have less than ten (10) registered participants. These registered participants are the only persons eligible to present or answer questions for the oral presentation and/or compete in the races. Substitutions of registered participants will be allowed up to the time of on-site registration. No substitutions shall be permitted after on-site registration. Each team shall designate two (2) of the registered participants to serve as team captains.

1.2.1 Eligibility Requirements

Registered participants at the Conference and National Competitions shall meet all of the following requirements:

- a. Be an undergraduate student majoring in engineering during the 2010-2011 academic year (defined as the time between August 2010 and June 2011). Students do not need to be enrolled during the entire academic year (e.g., students graduating in December, or students who were not in school during the fall term but are in school for the spring term.) Students that graduate during the course of the academic year and have begun graduate studies during the same academic year are eligible to compete if they meet the remaining requirements.
- b. Be members of an ASCE Student Organization in good standing (Section 1.1).
- c. Be National Student Members of ASCE. ASCE student membership numbers shall be required upon registration.
- d. Have contributed to the design and construction of the concrete canoe.

1.2.2 Term Limits

Registered participation shall not exceed three (3) years (consecutive or non-consecutive). There are no term limits for participation in other supportive roles. Registered participation is defined as being one of the official team members that present and/or paddle during a Conference or National Competition. There shall be no limit to the number of support personnel permitted to prepare the design paper, oral presentation, and assist at the races. All students, both undergraduate and graduate, are strongly encouraged to actively participate in their school's canoe project (concrete and materials design and testing, canoe design and construction, design paper, fundraising, oral presentation preparation, etc.), including support at the canoe competitions.

1.3 PUBLICITY

For publicity purposes, ASCE may use any or all canoes and papers entered in the National Competition for a period of one (1) year from the date of the competition. All associated transportation costs, etc. shall be paid for by ASCE.

1.4 TECHNICAL ASSISTANCE

The corporate sponsors of the National Concrete Canoe Competition™ sponsors are committed to providing product information, material samples and technical assistance to all competitors. Students are strongly encouraged to contact corporate sponsors directly to request samples and/or mixture proportion assistance as appropriate. Contact information for national sponsors can be accessed through the logo links available on the official NCCC web site at www.concretecanoe.asce.org.

1.5 SPONSORSHIP

The use of trade and company names for services, products, and intellectual property shall be permitted in the design report for informational purposes only. Sponsorship recognition shall be limited to T-shirts, other apparel, or other non-competition related material. Sponsors are not to be recognized on the Product Display (Section 10).

1.6 REQUESTS FOR INFORMATION (RFI)

Requests for Information (RFI) should be directed via e-mail to the Committee on National Concrete Canoe Competitions (CNCCC) at cnccc@asce.org. Official responses will be broadcast to the NCCC list server unless a specific request is made for privacy. **Teams are strongly encouraged to contact the CNCCC to avoid misinterpretation of rules at the Conference and National Competitions.** The cut-off date for submitting a RFI is Friday, February 18, 2011. Those received after this date will not be acknowledged or addressed. RFIs, with the exception of those that are private, will be accumulated and published to the NCCC list server in FAQ documents by the CNCCC on or about November 1, 2010 and March 1, 2011.

The NCCC list server is available as a forum for general questions and answers for anyone to use. **Teams are required to subscribe to the list server.** Teams are also responsible for all information provided in the rules and regulations, the general questions and answers from the list server, and information given at competitions from the date of the release of the information.

Students may join the canoe@ftl.com list server by sending an email to majordomo@ftl.com with a body of "subscribe canoe" or "subscribe canoe <your e-mail address>". For more information, send an email to majordomo@ftl.com with a body of "HELP".

1.6.1 Format for Request for Information

In order for the CNCCC to respond to the RFIs submitted via e-mail to the NCCC List Server in a timely manner, indicate the section(s) being referenced in the "Subject" of the e-mail (for example, "RFI Regarding Section 3.3.2, Aggregate Proportioning"), provide the particular sentence or paragraph in question along with the question(s) being asked. Please be as specific as possible when providing the questions. If questions pertain to materials or products (such as the legality of admixtures), teams should provide relevant data (such as technical data sheets) with their e-mails for CNCCC review.

1.7 GENERAL INFORMATION

General information on the competition as well as registration information for the National Concrete Canoe Competition each spring is located on the ASCE website (www.asce.org/students). Students shall be responsible for registration materials, design paper and Engineer's Notebook submittal deadlines published on these websites. Questions regarding national race qualifying procedures, etc. should be directed to the ASCE Student Services e-mail (student@asce.org) or phone 1-800-548-ASCE or 703-295-6000.

1.8 SPIRIT OF THE COMPETITION

Under the "Spirit of the Competition," the judges and/or the CNCCC may take disciplinary action, including warnings, point deductions, or disqualification of a team or entry for inappropriate use of materials, language, alcohol, uncooperativeness, or general unprofessional behavior of team members or persons associated with a team. The judges and/or the CNCCC have the final authority to determine what constitutes a violation of the "Spirit of the Competition" and may take appropriate action towards point deduction or disqualification.

1.9 APPEALS AND FINAL SCORE VALIDATION

1.9.1 Conference Competitions

Appeals at the conference level shall be filed by the designated team captains using the *Request for Clarification and Appeals Form* (Appendix B-4) provided by either the Conference Head Judge or the host school. At the Conference Competition, the judges will make every effort to resolve an appeal. Judges may, at their discretion, contact the CNCCC directly or with the assistance from Committee on Student Activities (CSA) representative on-site. All appeals shall be resolved at the Conference Competition before the Awards Ceremony. Judges' original score sheets (Appendix A) and final electronic score sheets shall be checked and officially ratified by the Conference Head Judge before the Awards Ceremony.

1.9.2 National Competition

Appeals at the national level shall be filed by the designated team captains using the *Request for Clarification and Appeals Form* (Appendix B-5) provided by the CNCCC. At the National Competition, the judges will make every effort to resolve an appeal with direct assistance from the CNCCC. All appeals shall be resolved before the Awards Ceremony. Judges' original score sheets (Appendix A) and final electronic score sheets will be checked and officially ratified by the National Head Judge and the CNCCC before the Awards Ceremony.

1.10 CANOE REMOVAL

It is the responsibility of the participating schools to remove their entire canoe and any associated debris from the host school site after the competition. The host school has the option to remove any remaining canoe debris from the site and bill the responsible school.

1.11 SAFETY

It is the responsibility of all participants to be knowledgeable of Occupational Safety and Health Administration (OSHA, www.osha.gov) policies. It is the responsibility of all participants to know about the materials with which they are working. (See "Laboratories" and "Hazard Communication" Safety and Health Topics). Participants should obtain and read material safety data sheets (MSDS) for each material with which they will be working. It is the responsibility of all participants to work in a safe manner in a safe workplace environment. (See

"Construction: Concrete and Masonry," "Personal Protective Equipment," and "Ventilation" Safety and Health Topics). Also see the "Silicosis Fact Sheet for Construction Workers" at www.osha.gov.)

Refer to Section 11 – RACE RULES AND REGULATIONS, in particular, Section 11.2, "Safety", in regards to safety on the water.

Section 2 – CANOE

CNCCC Intent – *The intent of this section is to provide the specifications for the canoe to be built. In general, teams are to construct a canoe that (a) can withstand the rigors of competition including the transportation to and from the conference and national events, (b) are constructed of materials that are in **strict compliance** with the rules and regulations, (c) has been built within the current academic year and constructed and finished by the students, and (d) passes the flotation test to the satisfaction of the judges and/or CNCCC.*

2.0 GENERAL

The canoe shall be built within the current academic year with the durability necessary to perform at both Conference and National competitions including transportation to and from competition events. Canoes shall be constructed and finished by the students themselves. For all intents and purposes, construction relates to the placement of concrete, reinforcement, and flotation materials; finishing relates to sanding, staining, painting, sealing and application of letters. The fabrication of the canoe mold and lettering may be created with assistance from outside sources/vendors.

The teams will be judged on their ability to replicate the hull design provided by the CNCCC. The dimensions provided are for exterior measurements without regard for hull thickness. Canoes are subject to an official weigh-in at the National Competition only (Appendix A-6) with the measured weight of the canoe compared to the weight reported on the *Compliance Certificate*.

2.1 STANDARDIZED HULL DESIGN

Teams are required to construct a canoe using a hull design that has been developed by the CNCCC. This canoe design is the same design that has been used in both the 2009 and 2010 ASCE National Concrete Canoe Competitions. In general, the 2011 canoe is a 20-foot long hull with a maximum beam width of approximately 31 3/16 inches located at a distance of approximately 10 feet, 2 inches from the bow. The length is defined as the end-to-end measurement of the canoe taking into account the outermost dimensions of the hull as measured at the gunwale. The measurement of the maximum beam width is defined as the outermost dimension of the hull skin. The canoe features an elliptical cross-sectional shape with 4 inch radial chines and flared sidewalls, 4 inches of bow rocker and 2.5 inches of stern rocker. The depth (or height) of the canoe varies from 14 to 16 inches along its length.

Dimensions such as, but not limited to, depths, radii of chines, and beam widths, are regulated and their values shall be replicated according to the specifications and drawings located on the www.concretecanoe.asce.org website. General plan, elevation and cross-section views are shown in Figure 2.1

Teams shall not make any modifications to the hull design (i.e., increase/decrease in length, width, height and/or rocker; change in cross-section shape; etc.). Other elements of the canoe to include, but not limited to thwarts, ribs (Section 2.3), and hull thickness needed to ensure that adequate structural capacity is attained shall not be measured and their dimensions and locations are at the discretion of the team.

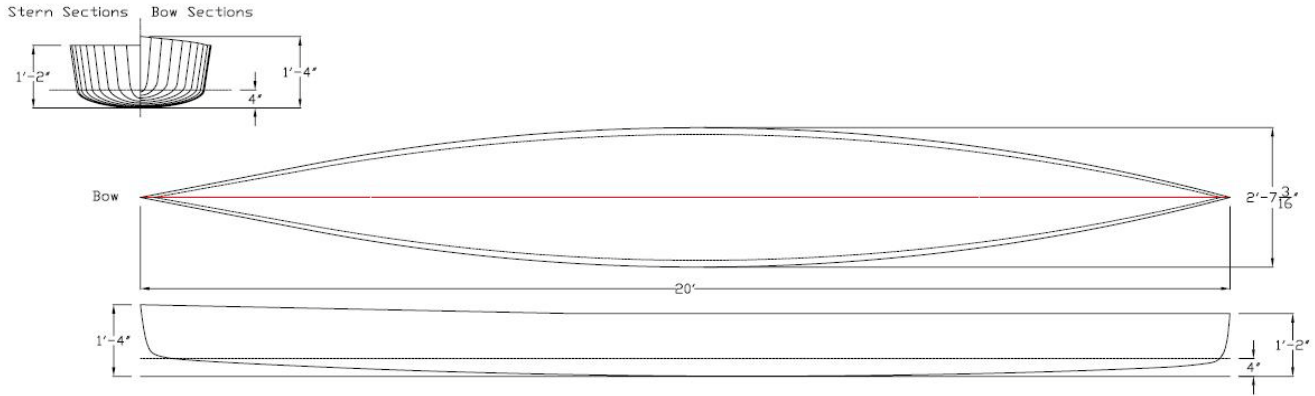

Figure 2.1 – Plan, Elevation and Cross-Sectional Views of 2011 Hull Design (not to scale)

2.1.1 DIMENSIONAL TOLERANCES

Teams shall be in general compliance with the dimensional constraints provided in Section 2.1. The tolerances for the length of the canoe shall be limited to +/- 1 inch, the width of the canoe at the widest point shall be limited to +/- ½ inch, and the rocker at bow and stern shall be limited to +/- ½ inch. If each of the dimensions are within the tolerances provided, then the canoe shall be deemed to be in general compliance and not subject to the 25 point deduction for dimensional constraints.

2.2 CONCRETE AND REINFORCEMENT

All concrete shall comply with all of the rules and regulations presented in Section 3 - CONCRETE. All materials not part of a concrete mixture, with the exception of materials that are used for flotation, shall be classified as a reinforcing material and shall comply with all of the specifications presented in Section 4 - REINFORCEMENT.

2.3 STRUCTURAL ELEMENTS

The use of structural elements such as, but not limited to, ribs, gunwales, thwarts, and bulkheads shall be permitted as long as they do not impede paddlers from safely exiting the canoe. All canoe components, external protrusions, and structural elements shall be made of materials that are in full compliance with Section 3 – CONCRETE and Section 4 - REINFORCEMENT. Any reinforcement used in the canoe components, external protrusions, and structural elements must comply with the thickness (Section 4.3.1) and percent open area (Section 4.3.2) requirements.

2.4 PADDLER RESTRAINTS

Fixed paddler restraints, such as straps, seatbelts, Velcro®, suction cups or any other item that attaches the paddler to the canoe or that interferes with the paddler safely exiting the canoe in the event of capsizing, are not permitted. The judges and/or CNCCC shall prohibit the use of any paddler restraints if safety is deemed an issue.

2.5 PADDLES

Canoes shall be paddled and not rowed. Paddles shall be single-bladed and may be straight bladed or bent. Spare paddles are permitted in the canoe during the races.

2.6 SEATS AND MATS

Seats cannot exceed a 20" x 20" x 20" maximum. Mats cannot exceed a 20" x 30" x ½" thick maximum. Seats and mats cannot be used together, at the same time, by one paddler. Each paddler may use either a seat or a mat as described above, but not both. The paddlers do not have to use the same types of seat or mat when paddling in the same race (for example, the seats may be of different dimensions; or one paddler uses a seat and another uses a mat). The seats and/or mats shall be available for review by the judges in the configuration that they will be used during Final Product judging.

2.7 SLIP RESISTANT MATERIAL

The use of non-skid tape or other slip resistant material is not permitted.

2.8 SPRAY SKIRTS

Post-construction applied devices that prevent water from entering the canoe, such as spray skirts, are not permitted. This includes any flotation material that is required to pass the flotation test.

2.9 GUNWALE

The gunwale shall be finished in such a way as to prevent injury to the paddlers (i.e., no exposed reinforcing or sharp edges). Gunwale caps or coverings that are not cast as an integral part of the original canoe shall not introduce a structural element to the canoe. Exterior gunwale caps that could provide rigidity (e.g., wood strips, plastic channels, or other rigid materials) shall be cut into sections no longer than two (2) feet each. Typical pipe insulation foam used as gunwale protection shall be permitted and is not considered as providing rigidity. No gunwale protection shall be permitted within two (2) feet of either the bow or stern ends of the canoe (Figure 2.2).

2.10 FLOTATION

2.10.1 Requirements

Canoes should be able to pass the flotation test either by the inherently buoyant design of the canoe or through the incorporation of flotation material in the design. For safety reasons, no hollow cavities or air bladders are permitted. Flotation material shall be solid blocks of material (such as foam, wood, etc.). Flotation material in the final form of particulates (such as foam peanuts, sawdust, and similar products) is not permitted. **All flotation material that is incorporated into the canoe must be encased in concrete.** Flotation can be placed at any location inside the canoe as long as it is below the gunwale line. The only exception to this requirement is flotation material that is added to a canoe that does not pass the flotation test (Section 2.10.2)

Gunwale caps or coverings (Section 2.9) are not permitted on the canoe during the flotation test. Once the canoe has been certified by the judges and/or the CNCCC as passing the test, gunwale caps and covers may then be added.

2.10.2 Flotation Test

The canoe shall pass a flotation test whereby the canoe floats horizontally, with a point within two (2) feet six (6) inches of the most exterior point of each end breaking the water surface simultaneously (Figure 2.2), within five (5) minutes of being completely filled with water. The canoe shall be certified as safe before entering any race, to the satisfaction of the judges and/or the CNCCC.

Canoes that do not pass the flotation test on the first attempt will automatically be assessed a 25-point deduction on the Final Product.

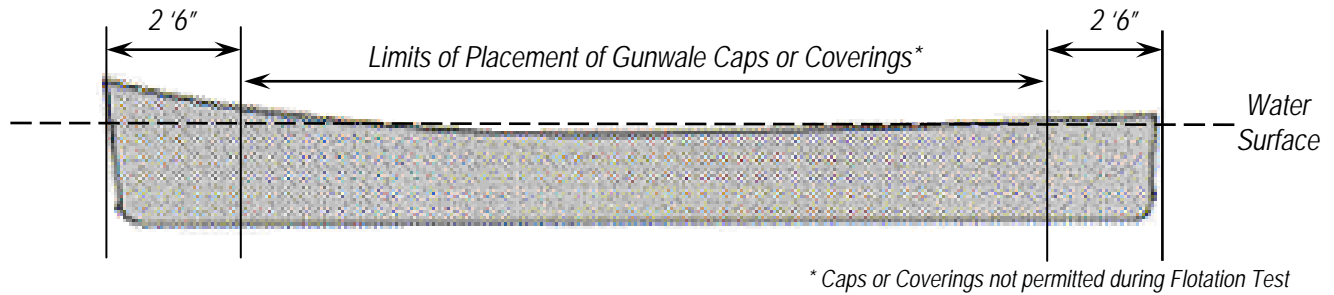

Figure 2.2 – Flotation Test and Limits of Gunwale Protection (Not to Scale)

2.10.3 Additional Flotation

In the event that a canoe does not pass the flotation test, teams shall be required to add additional flotation materials until the canoe does pass the test to the satisfaction of the judges and/or the CNCCC. Any additional flotation that is applied (including the materials used to attach it, i.e., tape) must be secured to the inside of the canoe and must be below the gunwale line (Figure 2.3). No flotation material shall be permitted on the top of the bow and stern sections. Gunwale caps and coverings shall not be permitted to serve as flotation material (Section 2.10.1).

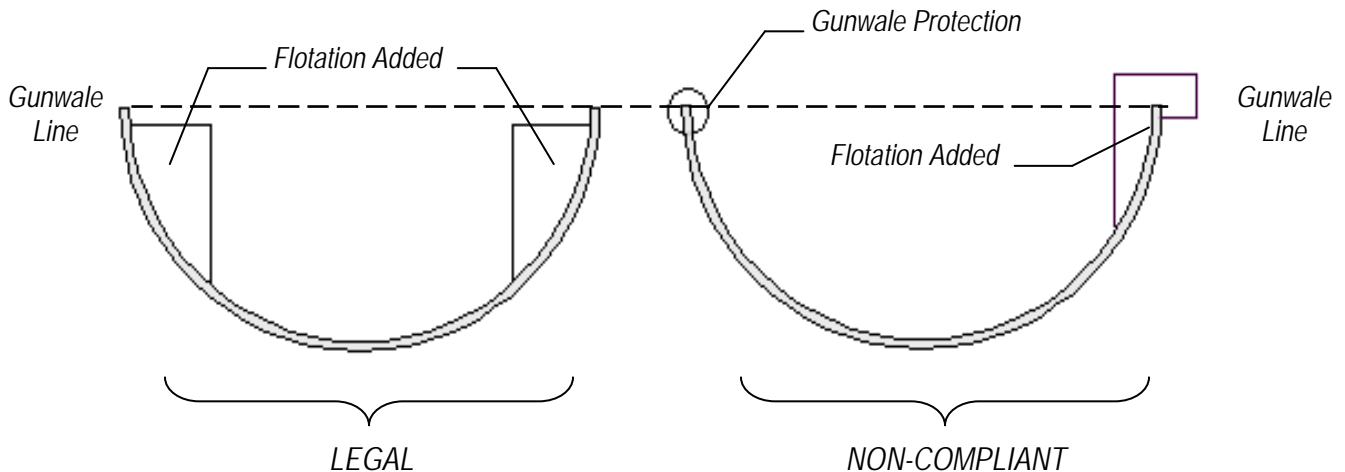

Figure 2.3 – Examples of Additional Flotation to Pass the Flotation Test

Flotation added at the Conference Competition shall remain in place for canoes that qualify for the National Competition. At the National Competition, the canoe with its added flotation shall be considered “as built, as delivered” and shall be judged accordingly.

2.11 REPAIRS

2.11.1 Repairs Made During Competition

During the competitions, inclusive of all events and transportation to and from the events, repairs can be made only with tape. Any type of tape is allowed. Canoes shall be assessed a deduction if tape is used as a result of a

durability issue. In the event of damage resulting from a collision with other canoes or circumstances beyond the students' control, deductions for a tape repair will not be assessed. Deductions for the use of tape for durability reasons do not apply to the tape used to secure a gunwale cap or cover or any tape that is added to secure flotation material necessary to pass the flotation test.

For each instance that tape must be applied to repair damage to a canoe resulting from collision or circumstances beyond the students' control, the team must first file a *Damage/Accident Report* (Appendix B-3) with the judges and/or the CNCCC and receive written approval before any tape can be applied to the canoe. During the Conference Competitions, the judges will inspect for tape usage as a repair material. During the National Competition, the judges and/or the CNCCC will inspect for tape usage as a repair material.

2.11.2 Repairs Made Between Conference and National Competitions

Repairs made to the original canoe or the request to reconstruct a canoe is subject to the requirements outlined in Section 2.11.4, "Repair Procedure Report and Reconstruction Request." Refinishing of the canoe (such as, but not limited to, additional sanding, repairing minor dent and cracks, and the reapplication of stains and sealers) constitutes a repair and is subject to the regulations of this section. Any proposed repairs shall be made using allowable materials as defined in Section 2.11.3, "Repair Materials," and are subject to review by the CNCCC. If reconstruction is granted by the CNCCC, the resulting canoe shall have the same hull design, materials, concrete mix design proportions, and performance characteristics of the original canoe.

2.11.3 Repair Materials

Pre-packaged or pre-mixed concrete, mortar, or grout is not permitted in the construction or repair of the canoe. Bondo®, epoxy, or similar materials are not permitted as patching or filler material at any time during the construction of the canoe, as a repair material for the canoe during the Conference and National Competitions, or as a repair material between the Conference and National Competitions.

Concrete and reinforcing materials used for repairs of the canoe between the Conference and National Competitions shall meet all of the requirements of Section 2.11.4, "Repair Procedure Report and Reconstruction Request," Section 3 – CONCRETE and Section 4 – REINFORCEMENT.

2.11.4 Repair Procedure Report and Reconstruction Request

2.11.4.1 General

In the event that the qualifying canoe is damaged during the Conference Competition or between the Conference and National Competitions, the Student Organization may patch, repair, and refinish the canoe following the submission and approval of a *Repair Procedures Report*. If the damage is beyond repair, the Student Organization shall submit a *Reconstruction Request* to the CNCCC to rebuild the canoe.

2.11.4.2 Submission

The *Repair Procedures Report* or *Reconstruction Request* form must be (a) formally requested from the CNCCC via e-mail at cnccc@asce.org, (b) completed, (c) signed by the team captain(s) and the faculty advisor, and (d) received by the CNCCC within five (5) business days following the completion of the Conference Competition or of the date that an incident damaging the canoe occurred. Samples of these documents are provided as Appendix B-1 and B-2, respectively.

2.11.4.3 Requirements

The *Repair Procedure Report* must contain sufficient information regarding the cause and extent of damage to the canoe and the proposed repairs (including, but not limited to, the methodology, repair materials, and area of damage) in order to enable the CNCCC to make a decision regarding the approval of repairs and granting the school the ability to repair the canoe. The CNCCC will review the *Repair Procedure Report* and, if necessary, will provide comments regarding the legality and suitability of the proposed repairs. Teams may be required to resubmit their *Repair Procedure Report* based on the comments provided by the CNCCC. Schools should not repair the canoe until final written approval is granted by the CNCCC.

If the CNCCC does not permit the team to repair the canoe (e.g., repair is due to issues, such as but not limited to, durability or constructability), the team shall be given an opportunity to make a determination of whether or not it can safely compete at the National Competition with a non-repaired canoe. If this requirement is not possible, the Student Organization shall forfeit to the designated alternate Student Organization concrete canoe team within their Conference.

The *Reconstruction Request* must contain sufficient information to enable the CNCCC to make a decision regarding the cause and extent of the catastrophic damage. The catastrophic damage to the canoe that occurs at the Conference Competition or as a result of an accident outside of the Conference Competition shall result in a thorough review of the durability and design of the canoe by CNCCC. The supporting documentation should include pictures of the damaged canoe, signed written explanation of events, police reports (if any) and other relevant documentation. The CNCCC will review the request and provide a decision as to whether or not the Student Organization shall be allowed to rebuild their canoe. Teams may be required to resubmit their *Reconstruction Request* based on the comments provided by the CNCCC. If it is determined by CNCCC that poor design resulted in the damage to the canoe, the *Reconstruction Request* will be denied and the 2nd place team will be invited to the National Concrete Canoe Competition.

In both of the aforementioned cases, if it is determined that the canoe may be re-built, the resulting canoe shall be of the same hull design, materials, concrete mix design, proportions, and performance characteristics of the original canoe. If this requirement is not possible, the Student Organization shall forfeit to the designated alternate Student Organization concrete canoe team within their Conference.

2.11.4.4 Point Deductions and Waiver

Canoes that are granted permission to repair their canoes by the CNCCC shall be assessed a 25-point deduction at the National Competition (Section 9.4.3). Canoes that are granted permission to reconstruct by the CNCCC shall be assessed a 50-point deduction at the National Competition (Section 9.4.4). The CNCCC reserves the right to waive the automatic deductions that may be assessed for repairs or reconstruction of a canoe with damage sustained due to accidents such as collisions during races. The CNCCC will review waivers on a case-by-case basis.

Section 3 – CONCRETE

CNCCC Intent – The intent of this section is to provide the specifications for the various concrete mixtures that teams may proportion for their concrete canoe. To raise awareness with regard to sustainability of concrete construction, the concrete mixtures must be “green.” In general, teams are permitted to use one (1) or more mixtures that (a) meet a maximum cement content (b) contain a specific amount of “sustainable” aggregate and, (c) attain fresh (plastic) unit weight in the range of 55-70 lb/ft³

3.0 GENERAL

Concrete mixtures, regardless of their use in the canoe, are defined as unique and independent mixes and shall comply with all of the requirements of this section. Pre-packaged or pre-mixed concrete, mortar, or grout is not permitted in the construction or repair of the canoe. Bondo®, epoxy or similar materials are not permitted at any time during the casting of the canoe (i.e., placement of concrete, reinforcement and flotation) but may be used in the construction of the canoe mold. Mixtures used as filler and patching materials during the construction or repair of the canoe (i.e., used for cracks, “bug holes,” low spots, etc.) shall be portland cement-based meeting all of the requirements of this section.

3.1 REFERENCES

The publications listed below form part of this specification to the extent referenced. The latest version of each standard shall govern wherever referenced. The publications are referred to in the text by basic designation only.

ASTM C 39/C 39M	Standard Test Method for Compressive Strength of Cylindrical Concrete Specimens
ASTM C 109	Standard Test Method for Compressive Strength of Hydraulic Cement Mortars (Using 2 in. or [50 mm]) Cube Specimens
ASTM C 125	Standard Terminology Relating to Concrete and Concrete Aggregates
ASTM C 127	Standard Test Method for Density, Relative Density (Specific Gravity) and Absorption of Coarse Aggregates
ASTM C 128	Standard Test Method for Specific Gravity and Absorption of Fine Aggregates
ASTM C 138/C 138M	Standard Test Method for Density (Unit Weight), Yield, and Air Content (Gravimetric) of Concrete
ASTM C 150	Standard Specification for Portland Cement
ASTM C 260	Standard Specifications for Air-Entraining Admixtures for Concrete
ASTM C 309	Standard Specification for Liquid Membrane-Forming Compounds for Curing Concrete
ASTM C 494/C 494M	Standard Specification for Chemical Admixtures for Concrete
ASTM C 496/C 496M	Standard Test Method for Splitting Tensile Strength of Cylindrical Concrete Specimens
ASTM C 595	Standard Specification for Blended Hydraulic Cements

ASTM C 618	Standard Specifications for Coal Fly Ash and Raw or Calcined Natural Pozzolan for Use as a Mineral Admixture in Concrete
ASTM C 979	Specifications for Pigments for Integrally Colored Concrete
ASTM C 989	Standard Specification for Ground Granulated Blast-Furnace Slag for Use in Concrete and Mortars
ASTM C 1116	Standard Specification for Fiber-Reinforced Concrete and Shotcrete
ASTM C 1157	Standard Performance Specification for Hydraulic Cement
ASTM C 1240	Standard Specification for Use of Silica Fume as a Mineral Admixture in Hydraulic Cement Concrete, Mortar, and Grout
ASTM C 1315	Standard Specification for Liquid Membrane-Forming Compounds Having Special Properties for Curing and Sealing Concrete
ASTM C 1438	Standard Specification for Latex and Powder Modifiers for Hydraulic Cement Concrete and Mortar

3.2 MATERIALS

3.2.1 Cementitious Materials

3.2.1.1 Hydraulic Cement

Shall meet the requirements of ASTM C 150, ASTM C 595 and/or ASTM C 1157, and shall react with water to form a binder.

3.2.1.2 Fly Ash

Shall meet the requirements of ASTM C 618, Class C or Class F, except loss-on-ignition shall not exceed 3%.

3.2.1.3 Metakaolin

Shall meet the requirements of ASTM C 618, Class N.

3.2.1.4 Slag Cement

Shall meet the requirements of ASTM C 989, Grade 100 minimum.

3.2.1.5 Silica Fume

Shall meet the requirements of ASTM C 1240.

3.2.2 Aggregate Blends

The blend of aggregates used to produce the concrete canoe mixture shall contain a minimum of two (2) different sustainable materials and shall satisfy the requirements of Section 3.3.2. Only one of the sustainable materials used may be glass microspheres (e.g., different grades of a particular product, similar products from different

sources, regardless of difference in gradation, specific gravity, particle shape, or composition, will be considered as one type of aggregate). Each of the sustainable materials used as an aggregate must constitute at least 25% of the total amount of aggregate (by weight). Multiple sources of glass microsphere are allowed and the total of the sources shall meet the requirement of at least 25%. Individual sources of glass microspheres do not need to meet the 25% requirement unless there is a sole source. To qualify for use as a sustainable aggregate the material shall be obtained through the process that either reduces the waste of potentially useful materials, reduces the consumption of fresh raw materials, reduces the energy usage, reduces air and water pollution by reducing the need for "conventional" waste disposal or lowers greenhouse gas emissions as compared to virgin production.

The CNCCC will consider the use of "non-deleteriously reactive aggregates" in concrete canoe mixtures. Reactive aggregates are those that are not considered totally inert (i.e. siliceous sand) and thus may participate in chemical reaction (typically pozzolanic) with other components of concrete mixture. Teams wishing to incorporate such aggregates must submit technical information to the CNCCC via e-mail for consideration as an approved aggregate source.

3.2.3 Fibers

Shall meet the requirements of ASTM C 1116 and shall be dispersed within the concrete matrix.

3.2.4 Admixtures

3.2.4.1 Water-Reducing (Normal, Mid-Range, and High-Range) and Set-Controlling Admixtures

Shall meet the requirements of ASTM C 494.

3.2.4.2 Air-Entraining Admixtures

Shall meet the requirements of ASTM C 260.

3.2.4.3 Coloring Admixtures/Agents and Concrete Pigments

Shall meet the requirements of ASTM C 979.

3.2.4.4 Polymer Modifier

Shall be a latex or re-dispersible powder formulated for use with hydraulic cements that meets the requirements of ASTM C 1438, Type II and, if warranted, shall be accounted for in the mass and volume calculations during mixture proportioning to ensure proper yielding of the concrete mixtures.

3.2.4.5 Specialty Admixtures

Specialty admixtures, such as but not limited to, shrinkage reducers, integral capillary waterproofers, and viscosity-modifying admixtures, do not currently have ASTM standards. The use of these admixtures is not prohibited, but requires pre-approval by the CNCCC.

Epoxy resins (such as acrylic, phenolic, and polystyrene resins), their curing agents, asphalt emulsions, or similar materials shall not be considered as specialty admixtures and are strictly prohibited. Teams wishing to

incorporate a material as a specialty admixture and have questions or concerns of whether it is an acceptable material shall contact the CNCCC via e-mail for a determination of its applicability.

3.3 REQUIREMENTS

3.3.1 Mass of Cementitious Materials

All concrete mixtures must contain hydraulic cement meeting the requirements of Section 3.2.1.1. The minimum amount of hydraulic cement is 30% (by mass) and the maximum amount is 50% (by mass) of the total cementitious materials content in any given concrete mixture (e.g., c/cm ratios shall be in the range of 0.30 to 0.50 for any given concrete mixture). In addition, the total amount of hydraulic cement meeting the requirements of Section 3.2.1.1 shall not exceed 400 lb/yd³ in any concrete mixture.

3.3.2 Aggregate Proportioning

The aggregate(s) selected shall constitute a minimum of 25% of the total weight of any concrete mixture. This weight percentage shall be based on a comparison of the total weight of all aggregates in the oven-dry condition, to the total weight of the concrete (based on yielded proportions). The amount of sustainable aggregates must comprise a minimum of 50% of the total amount of aggregate by weight. The total amount of aggregate used in concrete mixtures may vary from one mix to another; however, each mixture must contain aggregate (Section 3.2.2) in it to be in accordance with the rules and regulations.

3.3.3 Water-to-Cementitious Materials (w/cm) Ratio and Solids Content

There is no limit for the w/cm ratio in any concrete mixtures. The water content of all admixtures shall be taken into account in the determination of the w/cm based on the following equation

$$\text{Water in admixture} = \text{dosage} \times \text{cwt of cm} \times \text{water content} \times (1 \text{ gal}/128 \text{ fl oz}) \times (\text{lbs}/\text{gal of admixture})$$

The solids content of latex and liquid dyes/pigment solids, if used, are to be accounted for in the unit weight of the concrete mixtures. The contribution of solids from other admixtures shall be disregarded. The solids content from liquid admixtures shall be computed based on the following equation

$$\text{Solids in admixture} = \text{dosage} \times \text{cwt of cm} \times \text{solid content} \times (1 \text{ gal}/128 \text{ fl oz}) \times (\text{lbs}/\text{gal of admixture})$$

3.3.4 Allowable Density (Unit Weight)

The wet (plastic) density (unit weight) of any concrete mixture shall be between 55 and 70 lb/ft³. The allowable density is based on the reported density under the Yielded Proportions of Table 3.1. Each concrete mixture, regardless of its use, shall meet this requirement.

3.3.5 Curing

Concrete shall be cured after placement and finishing using an appropriate curing method. Liquid membrane-forming compounds for curing concrete that are certified to meet the requirements of either ASTM C 309 or ASTM C 1315, and stated as such on the product data sheet, may be applied to any portion of the canoe at the discretion of the team. Equivalent products shall be submitted to the CNCCC for consideration as an approved equal.

If an ASTM C 309 liquid membrane-forming curing compound is selected for use, it must be Type 1 (clear or translucent without dye) or Type 1-D (clear or translucent with fugitive dye), Class A (no restrictions on dissolved solids), with a volatile organic content (VOC) less than or equal to 350 g/L. If an ASTM C 1315 liquid membrane-forming curing and sealing compound is selected for use, it must be Type I (clear or translucent), Class A (non-yellowing) or Class B (moderate yellowing), with a VOC less than or equal to 350 g/L. The application of either a curing compound or curing and sealing compound to any portion of the canoe shall be limited to a maximum of two (2) coats following the manufacturer's recommended procedure for application and thickness.

3.4 DOCUMENTATION

3.4.1 Mixture Proportions Table

The proportions of each mixture of concrete used in building and repairing the canoe shall be summarized in a copy of Table 3.1, "Concrete Mixture Data Table," and shall be included in Appendix B of the Design Paper (Section 6.2.2.i). **Teams shall be responsible for mathematical accuracy and correct determination of all values and the proper use of significant digits.** Table 3.1 is available on the list server for download. Please refer to Appendix C, "General Guidelines for Concrete Mixture Data Table 3.1," for information and helpful hints on how to correctly complete the table.

3.4.2 Engineering Properties

The concrete density and strengths shall be reported in both English and SI units to the accuracies outlined in the industry standards (e.g., ASTM C 39, C 109, C 138 and C 496, etc.) on the *Compliance Certificate* (Section 7)

3.4.3 Material Technical Data Sheets

Material Technical Data Sheets (MTDS) for each material used in the construction of the canoe shall be presented under Tab D of the Engineer's Notebook (Section 7.1.2.d). This includes, but is not limited to, cementitious materials (including cement), aggregate (other than natural or manufactured sands), chemical admixtures, and pigments. **Material Data Safety Sheets (MSDS) are not equivalent documentation for MTDS.**

Any unaddressed equivalent materials shall be submitted to and approved by the CNCCC as alternatives before their application.

3.4.4 Aggregate Sample(s)

A 500-gram (min) representative sample of the composite aggregate and samples of the individual aggregates used in each concrete mixture shall be made available as part of the product display (Section 10.1.b). Samples shall be provided in either jars or plastic bags, and labeled accordingly.

3.4.5 Concrete Sample(s) Cylinders

3 in. x 6 in. or 4 in. x 8 in. samples of each concrete mixture used in the canoe shall be made available for compliance checking as part of the product display (Section 10.1.b). The sample(s) shall be a quality control (QC) test cylinder taken at the time of construction and be representative of the in-place density, color, consistency and make-up of the concrete(s) used in the canoe. The concrete cylinders shall be provided in two halves, preferably sawn in half, or broken by performing a splitting-tensile test in accordance with ASTM C 496.

Table 3.1 – Concrete Mixture Data Table

Mixture ID:			Design Proportions (Non SSD)		Actual Batched Proportions		Yielded Proportions		
Y_D	Design Batch Size (ft ³):								
Cementitious Materials			SG	Amount (lb/yd ³)	Volume (ft ³)	Amount (lb)	Volume (ft ³)	Amount (lb/yd ³)	Volume (ft ³)
CM1	Portland Cement								
CM2									
CM3									
CM4									
Total Cementitious Materials:									
Fibers									
F1	Fiber 1								
F2	Fiber 2								
Total Fibers:									
Aggregates									
A1	Aggregate 1	Abs:							
A2	Aggregate 2	Abs:							
A3	Aggregate 3	Abs:							
Total Aggregates:									
Water									
W1	Water for CM Hydration (W1a + W1b)								
	W1a. Water from Admixtures		1.00						
	W1b. Additional Water								
W2	Water for Aggregates, SSD		1.00						
Total Water (W1 + W2):									
Solids Content of Latex Admixtures and Dyes									
S1	Admixture 1								
S2	Admixture 2								
S3	Admixture 3								
P1	Pigment 1 (Powder Form)								
Total Solids of Admixtures:									
Admixtures (including Pigments in Liquid Form)			% Solids	Dosage (fl oz/cwt)	Water in Admixture (lb/yd ³)	Amount (fl oz)	Water in Admixture (lb)	Dosage (fl oz/cwt)	Water in Admixture (lb/yd ³)
Ad1	Admixture 1	lb/gal							
Ad2	Admixture 2	lb/gal							
Ad3	Admixture 3	lb/gal							
Water from Admixtures (W1a):									
Cement-Cementitious Materials Ratio									
Water-Cementitious Materials Ratio									
Slump, Slump Flow, in.									
M	Mass of Concrete, lbs								
V	Absolute Volume of Concrete, ft ³								
T	Theoretical Density, lb/ft ³ = (M/V)								
D	Design Density, lb/ft ³ = (M/27)								
D	Measured Density, lb/ft ³								
A	Air Content, % = [(T - D) / T x 100%]								
Y	Yield, ft ³ = (M/D)								
Ry	Relative Yield = (Y / Y _D)								

Section 4 – REINFORCEMENT

CNCCC Intent – The intent of this section is to provide the specifications for the various materials that teams may use to serve as the primary reinforcement in their concrete canoe. In general, teams are permitted to develop a reinforcement scheme that (a) uses materials that contain sufficient open space measured in terms of percent open area (POA), (b) the total thickness of the reinforcing layers is equal to or less than 50% of the total thickness of the reinforced concrete composite, and (c) the reinforcing materials do not have post-manufacturer applied coatings that enhance the properties of the reinforcement.

4.0 GENERAL

All reinforcement shall be covered in concrete. All material not part of a concrete mixture shall be classified as reinforcing material and shall comply with all of the specifications outlined below. This does not apply to materials that are used for flotation purposes.

4.1 REFERENCES

The publications listed below form part of this specification to the extent referenced. The latest version of each standard shall govern wherever referenced. The publications are referred to in the text by basic designation only.

ASTM C 1116 Standard Specification for Fiber-Reinforced Concrete and Shotcrete

4.2 MATERIALS

All of the materials serving as the primary reinforcement in the canoe shall have sufficient open space to allow for the mechanical bonding of the concrete composite. The determination of sufficient open space of the reinforcement is measured by percent open area (POA) as defined in Section 4.3.2. Solid mats or plates for reinforcing are not permitted. Solid mats and plates are described as reinforcing materials that require additional bonding agents or post-manufacturer perforations to keep the reinforcement from delaminating from the concrete composite (i.e., there is a lack of open space between the reinforcement sufficient for mechanical bonding to the concrete composite).

Fibers that are dispersed within the concrete matrix to improve the tensile and flexural characteristics of the concrete (ASTM C 1116) are considered as serving as secondary reinforcement and therefore are not subject to the measurements listed in Section 4.3.

4.3 MEASUREMENT

4.3.1 Thickness

The thickness of a layer of reinforcing is defined as follows: a single layer of the reinforcing is to be placed on a flat surface, a piece of plate glass, 6 mm (~1/4") or thinner, is to be placed on the reinforcing, the distance from the bottom of the plate to the top of the supporting flat surface is the thickness of a single layer. When subjected to the weight of the glass alone, the sum of all such measured thickness divided by the total thickness of the canoe wall or structural element (prior to staining or sealing) at any point in the canoe shall not exceed 50%. All canoe elements, including but not limited to, walls, ribs, gunwales, thwarts, bulkheads, etc., and the connections of structural elements to the canoe wall are subject to this rule. If individual rods or reinforcing bars are used in such a way that they cross each other, this use constitutes at least two (2) layers of reinforcing.

4.3.2 Percent Open Area

The minimum percent open area (POA) of any layer of reinforcing material is 40%. The determination of the POA of a particular reinforcement is obtained by using the following equation:

$$POA = \frac{\sum Area_{open}}{Area_{total}} \times 100\%$$

where: $\sum Area_{open}$ is the total open area (i.e., the area of the apertures)
 $Area_{total}$ is the total area of the reinforcement specimen

Depending on the size of the reinforcing material and apertures, magnification of the sample may be required. Magnification could be accomplished with the use of a photocopier, projecting it onto a wall with the use of an overhead projector, or digitizing an image of the sample. Values of areas, thicknesses and any other measurements needed to compute the POA may be obtained from direct measurements (using applicable methods and tools), values provided by manufacturer, or combination of the two. Figure 4.1 provides a sample calculation of POA.

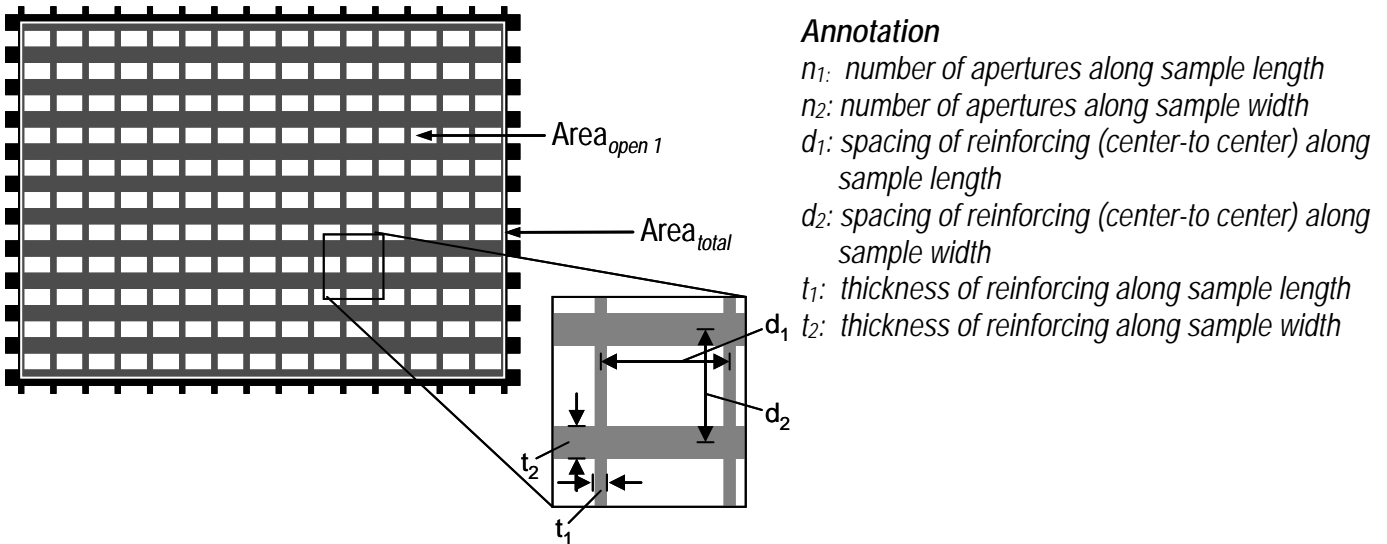

Given: A glass fiber reinforcing mesh with a 0.09 in² aperture size (0.30 in. by 0.30 in. aperture dimensions). The thickness of fibers along the sample length was determined to be 0.10 inches wide while the thickness along the sample width was found to be 0.20 inches wide. (See figure above)

Determine: Percent Open Area (POA) of the glass fiber reinforcing mesh

Solution:

$$d_1 = \text{aperture dimension} + 2(t_1 / 2) = 0.30 + 2(0.10/2) = 0.40 \text{ in.}$$

$$d_2 = \text{aperture dimension} + 2(t_2 / 2) = 0.30 + 2(0.20/2) = 0.50 \text{ in.}$$

$$\text{Length}_{\text{sample}} = n_1 d_1 = [(15) \cdot 0.40] = 6.0 \text{ in.}$$

$$\text{Width}_{\text{sample}} = n_2 d_2 = [(11) \cdot 0.500] = 5.50 \text{ in.}$$

$$\sum \text{Area}_{\text{open}} = n_1 \times n_2 \times \text{Area}_{\text{open } 1} = 15 \times 11 \times 0.09 \text{ in}^2 = 14.85 \text{ in}^2$$

$$\text{Area}_{\text{total}} = \text{Length}_{\text{sample}} \times \text{Width}_{\text{sample}} = 6.0 \text{ in} \times 5.50 \text{ in} = 33.0 \text{ in}^2$$

$$POA = \sum \text{Area}_{\text{open}} / \text{Area}_{\text{total}} \times 100\% = 14.85 / 33.0 \times 100 = \underline{45\%} (> 40\% \text{ min.}) \text{ OK!}$$

Figure 4.1 – Percent Open Area (POA) Determination and Sample Calculation

4.4 DOCUMENTATION

4.4.1 Hull Thickness/ Reinforcement and Percent Open Area (POA) Calculations

The measurements and calculations of the reinforcement(s) and hull thickness for the various canoe elements shall be presented under Tab C of the Engineer's Notebook (Section 7.1.2.c). Percent open area (POA) calculations of each of the reinforcement types used shall also be presented under Tab C.

4.4.2 Reinforcement Samples

A 12 in. x 12 in. square sample of each reinforcement material used in the canoe shall be made available for compliance checking as part of the product display (Section 10.1.b). If a bars, tendons or strands are utilized, a sample of 12 in. in length shall be provided.

4.4.3 Material Technical Data Sheets

Material Technical Data Sheets (MTDS) for each reinforcement material used in the construction of the canoe shall be presented under Tab D of the Engineer's Notebook (Section 7.1.2.d).

Section 5 – FINISHING

CNCCC Intent – The intent of this section is to provide the specifications for the various materials that teams may use to finish the surface of the canoes. In general, teams shall provide the names of the school and canoe at their specified heights and locations. Teams may (a) use integrally colored concrete, and (b) apply stains, sealers and/or paints to specified areas of the canoe.

5.0 GENERAL

All materials used for the canoe shall be environmentally safe.

5.1 REFERENCES

The publications listed below form part of this specification to the extent referenced. The publications are referred to in the text by basic designation only.

ASTM C 309	Standard Specification for Liquid Membrane-Forming Compounds for Curing Concrete
ASTM C 979	Specifications for Pigments for Integrally Colored Concrete
ASTM C 1315	Liquid Membrane-Forming Compounds Having Special Properties for Curing and Sealing Concrete

5.2 LETTERING

The school name (no initials) and the canoe name shall be prominently displayed on the exterior of the canoe, above the waterline, on both sides, with individual (not a continuous decal) letters. The school name shall consist of letters $4\frac{1}{2}'' \pm \frac{1}{2}''$ high; the canoe name shall consist of letters $3\frac{1}{2}'' \pm \frac{1}{2}''$ high. The height of the letters shall include any outlines, shadows, ascenders and descenders, etc., used. The height of the lettering may vary as long as it is within the specified range. Both upper and lower case letters may be used. If the complete name of the college or university is 31 characters or more (including all letters and spaces between words), the name may be abbreviated. The abbreviated name must still clearly indicate the specific college or university competing, and as applicable include state or city.

5.3 GRAPHICS

Graphics such as logos, symbols, etc. created using concrete coloring agents and pigments within the concrete mix design (i.e., integrally colored concrete) and/or stains as defined in Section 5.5 shall not be limited in dimension or frequency. Letters for canoe and school names that may be created using coloring agents and pigments are limited to the sizes outlined in Section 5.2. Any coloring agents or pigments used shall be in accordance with ASTM C 979.

5.4 PAINT AND ADHESIVE APPLIQUÉS

The use of paint and adhesive appliqués shall be limited to the lettering used for the school and canoe names (Section 5.2).

5.5 CONCRETE STAINS

Any stains that are applied to the canoe must meet the following requirements: commercially available; acid-based or water-based; maximum solids content of 10 percent; and a volatile organic content (VOC) less than or equal to 350 g/L. Commercially available thickeners specifically formulated for acid stains may be used in conjunction with the stains as long as the combination of stain and thickener does not exceed the maximum solids content and VOC as specified above. Additives such as glitter or other particulate material are not permitted. The application of any acid-based and/or water-based stain to any portion of the canoe shall be limited to a maximum of two (2) coats, as defined by the manufacturer, following the manufacturer's recommended procedure for application and thickness. The stains may be applied to any portion of the canoe at the discretion of the team. Equivalent products may be submitted to the CNCCC for consideration as an approved equal.

5.6 CONCRETE SEALERS

Concrete sealers (penetrating or surface coating) may be applied to any portion of the canoe at the discretion of the team. The sealer may be either (a) silane- or siloxane-based penetrating sealer with a minimum solids content of 20 percent and a VOC of less than or equal to 350 g/L or (b) liquid membrane-forming compound for curing and sealing that is certified to meet the requirements of ASTM C 1315, and stated as such on the product data sheet. Additives such as glitter or other particulate material are not permitted. Equivalent products may be submitted to the CNCCC for consideration as an approved equal.

If an ASTM C 1315 liquid membrane-forming curing and sealing compound is selected for use, it must be Type I (clear or translucent), Class A (non-yellowing) or Class B (moderate yellowing) with a VOC less than or equal to 350 g/L .

The application of sealer to any portion of the canoe shall be limited to a maximum of two (2) coats, as defined by the manufacturer, following the manufacturer's recommended procedure for application and thickness.

5.7 DOCUMENTATION

5.7.1 Material Technical Data Sheets

Material Technical Data Sheets (MTDS) for each material used in the construction of the canoe shall be presented under Tab D of the Engineer's Notebook (Section 7.1.2.d). This includes, but is not limited to pigments, paints, stains, sealers and curing compounds.

Any unaddressed equivalent materials shall be submitted to and approved by the CNCCC as alternatives before their application.

The MTDS must provide information clearly verifying that the materials used in the canoe, are in compliance with all of the specifications. In the event that the information is not provided (such as proprietary reasons), a letter from the company certifying that the materials used are in compliance with the specifications shall suffice. The letter shall be on company letterhead, state the specification being verified, and include name, title, phone number, and e-mail address of the individual(s) certifying compliance.

Section 6 – DESIGN PAPER

CNCCC Intent – The intent of this section is to provide the specifications for the Design Paper. In general, the Design Paper shall cover various areas related to the design and construction of the concrete canoe such as concrete and composite development and testing, project management, innovations and sustainable aspects of the design.

6.0 GENERAL

Scoring for each of the major sections comprising the body of the paper shall be based on the criteria in Appendix A-1. Only the body pages and appendices will be used for scoring. The report shall not contain any other information or documentation other than what has been outlined in Section 6.2.2 or it will be subject to deductions. All papers shall become the property of ASCE and may be used for publication and/or distribution. This applies only to the papers submitted for the National Competition.

6.1 REFERENCES

The publications listed below form part of this specification to the extent referenced. The latest version of each standard shall govern wherever referenced. The publications are referred to in the text by basic designation only.

ASCE *ASCE Author's Guide to Journals, Books and Reference Publications*

6.2 DESIGN PAPER

6.2.1 General Requirements

Except for the organizational chart, project schedule and design drawing, the Design Paper shall be presented on 8 ½" by 11" pages in portrait orientation. The organization chart shall be presented on an 8 ½" by 11" page and may be in either portrait or landscape orientation. The design drawing and project schedule shall be presented on 11" by 17" pages in landscape orientation and folded (Standard Z-fold) to fit within the report. All pages of the report, including the organization chart, project schedule and design drawing shall maintain a minimum of 3/4" margins on all sides.

Body text shall be in English and use 12-point, normal width character spacing, Times New Roman or Arial font. Section headings and subheadings shall be considered part of the body text, shall adhere to the margin requirements and may be of any font type or size. The text for the project schedule and design drawings do not need to meet the requirements of the body text, however, they should be of a font and size that is legible. Fonts other than Times New Roman or Arial may be used for canoe names so that they may stand out from the rest of the text (for example, **Excalibur**) as long as the font and size is legible.

The report shall consist of a single-sided report cover, single-sided pages for the body and appendices, and a back cover. A protective plastic cover in front of the report cover is permitted and does not count towards the page limit. No additional pages separating the appendices are permitted. No blank pages shall be inserted into the report.

Body pages, with the exception of the Table of Contents and Executive Summary, shall be numbered beginning with the number one (1). The Table of Contents and Executive Summary shall be on the same page and limited to a total of one (1) page, numbered with the lowercase Roman numeral *i*. Pages located in the appendices shall

be numbered in such a way that the appendix and page number are clearly listed (e.g., A-1, A-2, B-1, B-2; A1, A2, B1, B2; etc.) as appropriate.

Photographs, tables, line drawings, graphs, headers, and footers shall be permitted and shall be counted as part of the page limit defined herein. Captions used for any photographs, tables, line drawings, graphs or other figures shall be no less than 10-point, normal width, Times New Roman or Arial font. These items shall be restricted to the margins described herein.

Items such as page numbers, logos, section headings, etc. may be incorporated into the header and footer of the pages and are not subject to the font requirements of the body text. The header and footer may be located within the margin itself (i.e., outside of the body text limits). Material on the report cover may not be referred to in the body pages.

6.2.2 Format

The reports must adhere to the following format, and the following must be included at a minimum:

- a. **Report Cover:** Inside of the cover shall be left blank. Protective plastic cover is optional.
- b. **Table of Contents (Page *i*)**
- c. **Executive Summary (Page *i*):** At a minimum, the Executive Summary shall contain basic information about the school, conference, competition history, and performance level. List at a minimum, the canoe name, weight, length, width, depth, thickness, and color, as well as the engineering properties of the concrete (unit weight and strength) and type(s) of reinforcement used. Significant innovative features of the canoe's structural analysis and design, construction and project management shall be summarized here.
- d. **Content: The paper shall include the following sections in any proportion. Total content not to exceed a total of six (6) pages.**
 - 1) **Analysis:** Present the method(s) of analysis used to determine the structural and material design requirements. Include quantitative results from your analysis of forces, stresses, etc. Describe loading cases, support conditions, assumptions, and analysis tools used. Include the material property values for the concrete, reinforcement and composite that must be achieved according to your structural analysis. If applicable, discuss how requirements for bulkheads, thwarts or other structural elements are determined.
 - 2) **Development & Testing:** Present concrete and reinforcement materials considered, tested, and actually used in the construction of the canoe. Describe the method(s) used for testing. Use and refer to standard test methods where possible. Describe the initial (e.g., the baseline) concrete and reinforcement materials considered and why. Include quantitative test results from this baseline. If this is not the final mix and reinforcement used in the construction of the canoe, discuss the adjustments in material types and proportions considered and why. Provide manufacturer's recommended dosage for admixtures used and discuss the reasons for, and effects of, any deviation from the recommended amount. Describe the iterative process of going from your baseline to achieving the desired material and composite properties. Include the final concrete, reinforcement and composite test results. Provide the percent open area (POA) of the reinforcement(s) used. Compare the

final material properties and proportions to the design specifications determined in the analysis.

- 3) **Project Management and Construction:** Present the method(s) of project management and construction used. Present the project planning process as it relates to cost, time, quality, scope, and risk management involved throughout the project. Discuss the financial and resource allocation associated with material procurement, bill of materials and construction. List major milestone activities and how these were determined and achieved. Present critical path activities and describe how this critical path was determined. Provide the number of man-hours dedicated to the design, testing and construction of the canoe. Describe the process used for form material selection, form construction, placement of concrete and reinforcement, form removal and concrete finishing. Discuss the quality control and quality assurance practices as they apply to the entire project. Discuss the safety program implementation as it applied to the material testing and construction of the canoe.
 - 4) **Innovation and Sustainability** Include a description of new, innovative ideas that were implemented in this year's concrete canoe design, concrete mix or other areas of the project. Also discuss sustainable materials or other sustainable aspects of design and construction.
- e. **Organization Chart** (Page 7): Include a project team organization chart with team member names, role(s), tasks, or areas in which they made contributions at any time during the project.
 - f. **Project Schedule** (Page 8): Include a project schedule which depicts planned and actual execution dates for all major activities and milestones and clearly denote all activities on the Critical Path.
 - g. **Design Drawing** (Page 9): Include one (1) design drawing and bill of materials for the form. (Example is given in Figure 6.1. The title block and bill of materials can differ in appearance as long as they are in a standard engineering format.) The drawing shall show elevation, plan, and typical cross-section views of the form or formwork with applicable dimensions and other details as desired. A bill of materials listing all material quantities used to construct the form shall also be displayed. Up to seven (7) general notes highlighting specific details relevant to the form or formwork may be added. Additional details, cross sections, etc. may be added to clearly present construction techniques as necessary.
 - h. **Appendix A – References:** Parenthetical references following the format of *ASCE Author's Guide to Journals, Books and Reference Publications*. Papers using plagiarized material or failing to document sources appropriately shall be disqualified without appeal.
 - i. **Appendix B – Mixture Proportions:** A table listing every concrete mixture used in the canoe shall be included in Appendix B. For each of the final concrete mixture(s) used in the actual construction of the canoe, a "Concrete Mixture Data Table" (Table 3.1) shall be provided. Summaries of trial designs not used in the construction of the canoe are not permitted. One separate page for each data table shall be used.
 - j. **Appendix C – Bill of Materials:** A Bill of Materials (BOM) and production cost estimates shall be presented in Appendix C. The production cost estimate shall provide an estimate of the cost to manufacture the canoe for resale. The BOM shall list the name, quantity, unit price (market price if donated), and total cost of each material used for the construction of the canoe. Materials should include, but is not limited to concrete constituents (i.e., cementitious materials, aggregate,

admixtures, etc), reinforcements, stains, sealers, and lettering. A lump sum cost shall be provided for the mold used in the construction of the canoe. Costs associated with engineering, testing, construction (labor), prototypes, etc. are not to be included in the cost of the material or provided as a separate item. Unit prices should not include any mark-up.

An example of a Bill of Material table is provided below in Table 6.1. Teams may format the table as appropriate

- k. **Appendix D – Repair Procedures Report or Reconstruction Request (if necessary):** In the event that the qualifying canoe is damaged during or after the Conference Competition and if repair is required, either a *Repair Procedures Report* or *Reconstruction Request* shall be included as an appendix to the report. The CNCCC disposition and supporting documentation shall be presented in Appendix D, as well. (Note: Reports submitted for Conference Competitions will not require this appendix).
- l. **Back Cover:** This cover shall be left blank. Protective plastic cover is optional

Table 6.1 – Bill of Materials and Production Cost Estimate (Example)

Material	Quantity	Unit Cost	Total Price
Portland Cement, Type III	lbs	\$ / lbs	\$
Fly Ash, Class C	lbs	\$ / lbs	\$
Slag, Grade 120	lbs	\$ / lbs	\$
Aggregate A	lbs	\$ / lbs	\$
Aggregate B	lbs	\$ / lbs	\$
Welded Wire Mesh	sq. ft.	\$ / sq. ft.	\$

Vinyl Lettering	Lump Sum	\$	\$
Acid Stain	gal	\$ / gal	\$
Sealer	gal	\$ / gal	\$
Wooden Mold, complete	Lump Sum	\$	\$
Total Production Cost			\$

6.3 SUBMISSIONS

6.3.1 Conference Competition

For the Conference Competitions, each school shall provide five (5) bound copies of the Design Paper. **Electronic copies of the report are not be required at the conference level and shall not be requested by the host school.** All copies of the Design Paper must be received by the date specified by the conference host

school or be subject to penalties. Please note that the CNCCC does not dictate the deadlines for the submission of Design Papers at the Conference Competitions.

6.3.2 National Competition

For the National Competition, each school shall provide twelve (12) bound and one (1) electronic copy of the Design Paper. The electronic copy of the report shall be in Adobe Acrobat® PDF format and copied to a compact disc (CD). The electronic submission shall be considered the official and final version of both the Design Paper and Engineers Notebook. Substitutes will not be accepted at the National Competition. All copies of the Design Paper and Electronic Notebook must be received by the date specified in the invitation letter or will be subject to penalties. Appendix D provides information on the formatting of all electronic deliverables.

6.4 DESIGN PAPER DEDUCTIONS

Deductions will be assessed for infringements of the specifications, including but not limited to failure to submit a *Repair Procedure Report* or *Reconstruction Request* as an appendix (if necessary), design papers not formatted properly or received after deadline, and using plagiarized material or failing to document sources appropriately. Teams shall be made aware of deductions assessed against the Design Paper and have the opportunity to appeal the deductions. Section 13.7 provides further details regarding the appeal process.

Section 7 – ENGINEER’S NOTEBOOK

CNCCC Intent – The intent of this section is to provide the specifications for the Engineer’s Notebook. In general, the Engineer’s Notebook is intended to serve as a technical document, which contains supportive information related to the design and construction of the canoe. In addition, a Compliance Certificate is provided and is intended to certify that the registered participants meet all eligibility requirements and provide pertinent information regarding the canoe and concrete.

7.0 GENERAL

The Engineer’s Notebook is a technical document, which contains supportive information related to the design and construction of the canoe such as a certificate of compliance, photographs of the various stages of construction, hull thickness/reinforcement calculations, percent open area calculations, and technical data sheets of the products used in the canoe.

7.1 REFERENCES

The publications listed below form part of this specification to the extent referenced. The latest version of each standard shall govern wherever referenced. The publications are referred to in the text by basic designation only.

ASTM C 39	Standard Test Method for Compressive Strength of Cylindrical Concrete Specimens
ASTM C 109	Standard Test Method for Compressive Strength of Hydraulic Cement Mortars (Using 2 in. or [50 mm]) Cube Specimens
ASTM C 138/C 138M	Standard Test Method for Density (Unit Weight), Yield, and Air Content (Gravimetric) of Concrete
ASTM C 496	Standard Test Method for Splitting Tensile Strength of Cylindrical Concrete Specimens

7.2 GENERAL REQUIREMENTS

Each team shall provide one (1) copy of an Engineer’s Notebook as part of the Product Display (Section 10). The Engineer’s Notebook shall contain only the information and documentation as outlined herein or points will be deducted. Additional information such as, but not limited to, structural calculations, testing results, concrete mix designs not used in the canoe, or material safety data sheets (MSDS) shall not be added to the notebook. All pages shall be 8 ½” x 11”, with tabs (separators) and contained within a three-ring binder.

For the National Competition, each school shall provide one (1) electronic copy of the Engineer’s Notebook. The electronic copy of the Engineer’s Notebook shall be in Adobe Acrobat® PDF format and copied to the same compact disc (CD) that contains the Design Paper. Pictures with titles may be provided in either PDF or .jpeg format. **Failure to provide a complete electronic copy of the Engineer’s Notebook by the date specified in the registration materials indicated in the invitation letter will result in penalties assessed against the Design Paper.** The electronic submission of the Engineer’s Notebook overrides all other submissions and will be used in the official judging. No new submissions will be accepted regardless of timing or omissions. Appendix D provides information on the formatting of all electronic deliverables.

Electronic copies of the Engineer's Notebook are not required at the conference level and shall not be requested by the conference host school.

7.2.1 Format

The following materials in the following order shall be provided:

- a. **Table of Contents** (include school name and canoe name at the top of the sheet)
- b. **Tab A – Compliance Certificate:** Provide one (1) original and signed *Compliance Certificate*, limited to one (1) single-sided page. The certification shall be presented on an 8 ½" by 11" page in either portrait or landscape orientation. There are no margin requirements. Body text shall be in English and use 10- or 12-point, normal width, Times New Roman or Arial font. Any headings and subheadings may be of any font type or size. The following must be included at the minimum:
 - 1) School Name and Canoe Name
 - 2) A statement certifying at a minimum that
 - a) the construction and finishing of the canoe has been performed in complete compliance with the rules and regulations of the National Competition;
 - b) the registered participants at the Conference/National Competition are qualified student members and National Student Members of ASCE, and meet all of the eligibility requirements as specified in the rules and regulations of the National Competition;
 - c) the canoe has been completely built within the current academic year of the competition;
 - d) the team acknowledges that all material safety data sheets (MSDS) have been read by the project management team, and
 - e) the team acknowledges receipt of the *Frequently Asked Questions* (FAQ)
 - 3) The names and ASCE National Member ID Numbers of all of the registered participants.
 - 4) A table summarizing the following dimensions and parameters of the canoe and concrete:
 - a) maximum length, maximum width, maximum depth, average thickness, overall weight
 - b) concrete density/densities, compressive strength(s), tensile strength(s), composite flexural strength(s) and air content(s)
 - 5) All dimensions shall be in English units and reported in feet and inches. The overall measured weight of the canoe shall be rounded to the nearest pound. The concrete density and strengths shall be reported in both English and SI units to the accuracies outlined in the industry standards (e.g., ASTM C 39, C 138, C 109 and C 496, etc.). The day of testing (i.e., 7-day, 28-day, etc.) for the reported strengths shall also be denoted.

Note: The weight of the canoe listed on the *Compliance Certificate* is taken as the official weight reported by the team. It is this weight that is compared to the value recorded at the weigh-in at the National Competition.

- 6) Shall be signed and dated by at least one (1) team captain and one (1) faculty advisor certifying that the aforementioned information is valid. The phone number and e-mail address for both the team captain and the faculty advisor shall be provided.
- c. **Tab B – Construction Photographs:** Provide photographs highlighting the construction of the concrete canoe. Photographs shall be limited to a maximum of two (2) per single-sided page. The photographs may be color or black/white, digital or film, with captions provided. Construction photographs shall be submitted as one (1) electronic file. A total of sixteen (16) photographs are required with a breakdown as follows:
- 1) Six (6) of mold construction showing the fabrication of cross sections, assembly of the mold and the application of any coatings prior to canoe construction.
 - 2) Six (6) of canoe construction showing concrete placement, reinforcement installation and if applicable, flotation placement.
 - 3) Four (4) of finishing techniques depicting any sanding/patching and the application of paint, sealer and/or graphics.
- d. **Tab C – Hull Thickness/Reinforcement and Percent Open Area Calculations** (limit of 3 pages): Present the measurements and calculations of the reinforcement(s) and hull thickness for the various canoe elements (i.e., walls, ribs, gunwales, thwarts and bulkheads) as applicable (Section 4.3.1) as well as percent open area calculations (4.3.2).
- e. **Tab D – Material Technical Data Sheets (MTDS):** Present MTDS for each of the materials used in the construction of the canoe, including but not limited to binders (other than cement), aggregate (other than natural or manufactured sands), chemical admixtures, paints, stains and sealers. Originals or photocopies are acceptable. Please note the Material Technical Data Sheet related to products is not the same as a Material Safety Data Sheet (MSDS).

The MTDS must provide information clearly verifying that the materials used in the canoe, such as stains and sealers, are in compliance with all of the specifications. In the event that the information is not provided (such as proprietary reasons), a letter from the company certifying that the materials used are in compliance with the specifications shall suffice. The letter shall be on company letterhead, state the specification being verified, and include name, title, phone number, and e-mail address of the individual(s) certifying compliance.

For ease of review, tabs should be provided for each material that a MTDS is being provided for labeled as D-1, D-2, D-3, etc., as appropriate (for example, D-1 Blast Furnace Slag, D-2 Class C Fly Ash, etc.)

Section 8 – ORAL PRESENTATION

CNCCC Intent – The intent of this section is to highlight the details of the Oral Presentation. In general, each team is to conduct a live, five (5) minute technical presentation highlighting the various aspects of the project followed by a seven (7) minute question and answer period. The presentation can be made by any of the ten (10) registered participants. Presenters include those with speaking parts, and individuals operating the computer or projectors during the course of the presentation.

8.0 GENERAL

An oral presentation (maximum of 5 minutes, 5 seconds) shall be required for each participating school. The five seconds is a grace period to account for timer (stopwatch) reaction. All technical presentations shall be conducted in a professional manner. Oral presentations shall be presented in English. Presentation order shall be randomly selected before the competition begins and shall be provided at the time of on-site registration. The oral presentations shall be open to the public for viewing.

An additional seven (7) minute period shall be permitted for judges' questions immediately following the oral presentation. Questions are not to be permitted by members of the audience. The time required to set up equipment shall not exceed four (4) additional minutes for each school and the time required to take down shall not exceed four (4) minutes for each school.

8.1 EQUIPMENT

The host school shall provide two (2) grounded power plugs, two (2) projector screens, and a computer projection unit for general use during the oral presentation. The host school shall provide a stage diagram two (2) weeks prior to the competition. Access to the staging area may be limited. The ability to use props may be limited by this restricted access. The individual school making a presentation shall furnish any additional equipment necessary.

8.2 PRESENTERS

Presenters may be any of the registered participants who officially sign-in at registration (Section 1.2). Presenters include those with speaking parts and individuals operating the computer or overhead projectors during the course of the presentation.

Teams shall make a live presentation. The use of video shall be permitted. Teams shall not pre-record any speaking parts. No handouts or other materials shall be given to the judges as part of the oral presentation. All team members participating in the presentation shall be on stage and available for judge's questions.

8.3 DEDUCTIONS

Deductions will be assessed for infringements of the specifications, including but not limited to, exceeding the official time limit of 5 minutes 5 seconds (5:05) and not following the live presentation format.

Section 9 – FINAL PRODUCT (Canoe and Cutaway Section)

CNCCC Intent – The intent of this section is to (a) describe the various aspects of Final Product judging and (b) provide guidance to the judges on the criteria for their assessments. The Final Product is based on scores assigned by the judges on the team's ability to replicate the hull design, the canoe's overall aesthetic appeal and deductions for items such as the inability to pass the flotation test on the first attempt, the use of tape as a repair material for non-accident related damage, and non-compliance with the rules and regulations

9.0 GENERAL

The Final Product (canoe, cutaway section and product display) shall be consistent with the Design Report and Oral Presentation. Final Product assessment consists of assigning a score to the canoe based on the team's ability to replicate the hull design and its overall aesthetic appeal and by applying deductions based on the inability to pass the flotation test on the first attempt, the use of tape as a repair material for non-accident related damage, and non-compliance with the rules and regulations. The durability of the canoe is based solely on the use of tape as a repair material for non-accident related damage and the canoe's ability to complete the required events. The durability of a canoe shall be assessed by the judges at the Conference Competition and by the judges and/or CNCCC at the National Competition.

9.1 AESTHETICS

9.1.1 General Requirements

Judging shall assess the aesthetic appeal of the "as-built, as-delivered" product. At the time of judging, all gunwale caps and coverings shall be removed. Aesthetics judging may take place before or after the canoe has been certified as passing the flotation test. In the event that judging takes place after the flotation test, teams that required additional flotation to pass the test shall temporarily remove the added flotation in order to be judged. Immediately after judging has been concluded, the teams shall place the flotation back in its original position.

Per Section 2.10.3, flotation added at the Conference Competition shall remain in place for canoes that qualify for the National Competition. At the National Competition, the canoe with its added flotation shall be considered "as built, as delivered" and shall be judged accordingly.

For aesthetics judging, all canoes shall be assembled in a common area. Canoes shall be displayed on display stands designed to support the canoe at a clear height of 2.5 to 4 feet below the canoe. No lighting, sound, or canopies shall be permitted at the time of judging.

9.1.2 Judging Criteria

The judges shall assess the aesthetics/workmanship of a canoe, cutaway section, and product display (Section 10) based on his/her own criteria, but in accordance with the Final Product score sheet as shown in Appendix A-3. To assess the team's ability to replicate the hull design provided by the CNCCC, the judges will make appropriate measurements of the canoe's length, width, heights, bow/stern rocker, and cross sectional shape. The cross sectional shape will be gauged using three (3) templates, one from each third of the canoe's overall length, at stations to be determined by the CNCCC prior to the start of the conference competitions. These stations may not be the same used at the National Competition, and the CNCCC reserves the right to increase the number of templates used.

Deductions shall be assessed against canoes that do not have the correct length, width, height and/or rocker. The assessment of the team's ability to meet the desired cross-sectional shape is subjective, using the templates as a method to assist in judging, and will be taken into account on the judge's rating sheet (Section 9.1.3).

9.1.3 Scoring

Prior to aesthetics judging, each judge will receive a rating sheet that lists each canoe in the competition (Appendix A-3). For each canoe in the competition, there shall be one (1) aesthetics score from each judge. Completed sheets are to be turned in to the appropriate competition official at the end of aesthetics judging. Any attempt to influence the votes of the judges is not allowed and is cause for disqualification and immediate dismissal from the event. Judges' decisions regarding this are final and may not be appealed.

9.2 DURABILITY

9.2.1 General Requirements

Canoes should be tough enough to survive the rigors of the Conference Competition, the National Competition, and transportation to and from the various events.

9.2.2 Allowable Repair Materials

During the competition, repairs can be made only with tape. Any kind of tape is acceptable. Bondo®, epoxy, or similar materials are not permitted as a repair material for the canoe during the Conference and/or National Competitions (Section 2.10.3).

Bondo®, epoxy, or similar materials are prohibited from being used as a repair material for canoes that have qualified for the National Competition. Materials used to repair the canoe in the period between the Conference and National Competition shall be in accordance with all of the rules and regulations relating to the construction of the canoe, in particular, but not limited to, Section 3 – CONCRETE and Section 4 - REINFORCEMENT.

9.2.3 Scoring (Deduction) Criteria

Durability is assessed by the judges at the conference competition and by the judges and/or CNCCC at the national competition and is based on the use of repair materials and the canoe's ability to complete the required events. The following is the list of standard deductions that can be implemented for durability issues:

- a. If a tape repair is required to continue racing for reasons other than those outlined in Section 9.2.4, "Limitations", the school will automatically receive a 25-point deduction on the Final Product.
- b. Failure of the canoe to complete all preliminary sprint and endurance events will result in the canoe receiving zero Final Product points for the competition.
- c. The use of Bondo®, epoxy, or similar materials as a repair material will result in the team automatically receiving zero Final Product points for the competition.

9.2.4 Limitations

In the event that the damage to canoe occur due to collision with other canoes or due to other circumstances beyond the students' control, deductions for the use of tape as a repair material shall not be assessed against a team. In the event of damage resulting from a collision or circumstances beyond the students' control, the team

must first file a *Damage/Accident Report* (Appendix B-3) with the judges or CNCCC and must receive written approval before any tape can be applied to the canoe. This applies to all instances that tape will be added (that is, permission to use tape to repair damage in one location does not give the team the freedom to put tape elsewhere on the canoe; permission is needed for each and every instance)

Deductions for the use of tape for durability reasons do not apply to the tape used to secure a gunwale cap cover or any tape that is added to secure flotation material necessary to pass the flotation test (Section 2.10.1).

9.3 CUTAWAY SECTION

A full-scale cutaway section representative of both the raw and finished canoe shall be judged as part of the Final Product and shall be presented alongside the canoe. At least three (3) feet of the cutaway section shall demonstrate the concrete casting, finishing, and reinforcement techniques used (i.e., the three-foot section should show concrete placement and finishing in various stages). The cutaway section shall also show the mold, however, it does not count towards the required length of the cutaway section. No additional pictures or text shall be included with the exception of labels properly identifying specific construction elements of the cutaway section.

9.4 FINAL PRODUCT DEDUCTIONS

9.4.1 Durability

The deductions for durability are outlined in Section 9.2.3, "Scoring (Deduction) Criteria."

9.4.2 Flotation "Swamp" Test

Canoes that do not pass the flotation "swamp" test on the first attempt (Section 2.10) shall be assessed an automatic 25-point deduction.

9.4.3 Standard Deduction for Repairs (*applicable at the National Competition only*)

Teams that are granted permission to repair their canoes by the CNCCC shall be assessed a 25-point deduction at the National Competition. This section does not apply to Conference Competitions. The CNCCC reserves the right to waive the automatic deductions that may be assessed for repairs or reconstruction of a canoe with damage sustained due to accidents such as collisions during races.

9.4.4 Standard Deduction for Reconstruction (*applicable at the National Competition only*)

Teams that are granted permission to reconstruct by the CNCCC shall be assessed a 50-point deduction at the National Competition. This section does not apply to Conference Competitions. The CNCCC reserves the right to waive the automatic deductions that may be assessed for repairs or reconstruction of a canoe with damage sustained due to accidents such as collisions during races.

9.4.5 Non-Compliance with the Specifications

Deductions will be assessed for infringements of the specifications, including but not limited to, canoes that cannot withstand the rigors of competition, improper finishing of canoe (paint, stain, appliqué, coating, or other materials violation), non-compliant concrete and/or reinforcement, dimensional (length, width, height, and/or rocker) violations. Teams shall be made aware of deductions assessed against the Final Product and have the opportunity to appeal the deductions. Section 13.7 provides further details regarding the appeal process.

Section 10 – PRODUCT DISPLAY

CNCCC Intent – The intent of this section is to describe what items are required for the Product Display. In general, teams shall provide the following: tabletop display, concrete cylinder(s), sample(s) of concrete aggregate(s), seats and/or mats, and the Engineer's Notebook.

10.0 General Requirements

Each team shall provide a Product Display with the following configuration:

- a. Conference Table – standard table, with maximum dimensions of 30" (W) x 96" (L) x 29" (H). Each team shall provide their own table (may include a table cloth). See example to the right:
- b. Table Top Display – the tabletop display, including overhangs, projections, and braces, shall fall wholly within a 30" (W) x 96" (L) x 48" (H) box. The tabletop display shall be placed on the table and provide enough space to accommodate all information and samples. It will only be viewed from only one side that opens to the front of the table.



10.1 Required Information and Samples

The tabletop display shall, at a minimum:

- a. Convey information in the design paper including photographs, charts, etc. There are no specific requirements on the amount of or manner in which the information is conveyed. Teams shall use their discretion and judgment in the determination of the material it wishes to display.
- b. Display sample(s) of concrete aggregate (composite and individual), concrete cylinder(s), and raw reinforcement sample(s) and the Engineer's Notebook (Section 7).
- c. Teams will also be required to bring their seats/mats (Section 2.5) for measurement check during the product display review; however, they do not need to be included as part of the display.

10.2 Restrictions

- a. Displays must be designed to be self-supporting and may be secured to the table. Nothing shall be taped, mounted or attached in any form or manner to the walls, doors, or floors, etc. The driving of nails, tacks or screws into the floors, walls, columns, ceilings or trim will not be permitted.
- b. Displays shall not include electronic devices of any kind (such as, but not limited to, laptops, lighting, sound equipment, video equipment, radios, loudspeakers or any other noise-creating devices).
- c. No sponsor-related items (such as sponsor list, logos, etc.) shall be part of the display.

10.3 Scoring

The Product Display will account for 10 percent of the Final Product (Section 9) score. Any product display that is not in compliance with this section shall be subject to a deduction in Final Product.

Section 11 – RACE RULES and REGULATIONS

11.0 GENERAL

A total of five (5) races shall be held: women's slalom/endurance (3 women), men's slalom/endurance (3 men), women's sprint (2 women), men's sprint (2 men), and co-ed sprint (2 men and 2 women).

11.1 RACE RULES

The following general rules apply to the paddlers:

- a. Schools shall use the same team members in both the preliminary and final heats of any particular race.
- b. In the event that a paddler is injured prior to a preliminary race, a substitution may be made. Such a substitute paddler shall be one of the original five (5) of the same gender registered on the team.
- c. In the event of an injury that prevents a paddler from further competition after the preliminary race has been completed, the injured person or a substitute shall be in the canoe in subsequent races. However, this person or these persons shall not be allowed to paddle. The substitute passenger shall be one of the original five (5) of the same gender registered on the team.
- d. In the event that a team cannot field the proper number of paddlers of the required gender, substitute passengers of opposite gender shall be allowed, but these substitutes shall not be allowed to paddle. Substitute passengers shall be of the team's registered participants.

Canoes competing in the distance races shall compete against the clock in a timed single event. All other races shall include timed preliminaries, grand final and a petite final based on the top ten (10) qualifying times from the preliminaries. Points shall be awarded based on the finish times in the finals. In the event that finals cannot be conducted or the host school determines before the race competition starts that separate finals heats will not be run, the preliminary times shall be used as the final times. If a grand or petite final entry becomes disqualified, scratched, or cannot finish the final, all positions below that finisher shall move up one place in the ranking. This includes the next highest qualifier from the preliminaries.

In the event that all of the race events cannot be conducted (for example, the distance races were completed but the sprint races could not be completed), the race scores (Section 13.4) for all of the completed races shall be accounted for in the overall competition score. By no means should the race scores be adjusted to account for races not held/completed.

In the event that none of the race events can take place, the overall competition score shall be based solely on the results of the academic portion of the competition (Design Paper, Oral Presentation, and Final Product) with the maximum possible score being 75 points.

11.1.1 Conference Competitions

Depending on the number of entrants at the conference competitions, host schools shall make a decision on having grand and petite finals for the various sprint races. The host school shall inform all teams prior to the competition if both preliminaries and finals will be held or if the sprint races will be based on the best times.

11.1.2 Lane Position and Heat Assignments

Lane position and heat assignments shall be randomly selected before the competition begins and shall be provided at registration. Course and turn directions shall be announced as soon as they can be determined by the course layout and site conditions. The regional and national host school shall provide a diagram or map to the participants outlining the layout of the course prior to the races.

11.1.3 Sportsmanship

Commonly accepted rules of sportsmanship shall prevail. There shall be strict enforcement of racing etiquette by the CNCCC and the judges. Any use of paddles to intentionally strike at an opponent's canoe, or at any person, shall cause the disqualification of the offending team from the event. Good sportsmanship, cooperation, fellowship, and the spirit of competition shall be strictly adhered to.

Any canoe willfully interfering with the performance of any other canoe or participant in a race shall be automatically disqualified from that event. Spectators interfering with the performance of contestants shall be asked to leave and may cause the disqualification of affiliated contestants. Contestants or spectators interfering with the performance of the competition, judges' ruling, or protests, may cause the disqualification of the affiliated school.

11.1.4 Interference

If interference occurs, a team captain may appeal to the CNCCC. At the Conference Competitions, the team captain shall appeal directly to the head judge. Once presented with the appeal, the judges shall:

- a. Disqualify a team that has willfully interfered with another team. If the interference is not deliberate, then the team should not be disqualified.
- b. Disqualify any canoe that willfully fails to adhere to course boundaries resulting in interference with another canoe. If the interference is not deliberate, then the team should not be disqualified.
- c. Allow any team(s) directly affected by interference the option to rerun the heat in a timed event. Times from the rerunning of the heat shall be used as the official time for the heat. Heats shall be rerun after a minimum of ten (10) minutes.

11.1.5 Appeals

Requests for rule interpretations and/or appeals during Conference Competition shall be presented to the Conference Head Judge by the designated team captain(s). Requests for rule interpretations and/or appeals during the National Competition shall be presented to the CNCCC by the designated team captain(s). Such request or appeals must be lodged before the start of the next heat or in the case of the distance races, before the next three (3) canoes finish the race. **Appeals shall be made by a team captain.** The decisions made by the judges and/or CNCCC concerning all aspects of the race and judging shall be final. Conference head judges may contact the CNCCC in order to clarify rule interpretations and to discuss appeals that have been lodged by team captains.

11.2 SAFETY

11.2.1 Power Rescue Boat

A powered rescue boat shall be on the water during all the races. If a powered rescue boat is not available, the races shall not take place.

11.2.2 Safety Director

A safety director shall be located in a strategic position to observe the activities, especially those near the starting and docking area. The safety director is responsible for stopping all activities involving violations of any of the safety rules.

11.2.3 Canoe Safety

All canoes shall be able to pass a flotation test before entry in any race (Section 2.10.2); otherwise, it shall not be permitted to compete. If flotation materials are necessary to pass the flotation test, the canoe shall contain these same flotation materials during the race (Section 2.10.3).

Any entry deemed unsafe or hazardous by the judges shall not be permitted in the water unless corrective measures are taken. If corrective measures are not or cannot be made the entry shall be disqualified from further competition. If repairs must be made to an entry prior to any race, the judges may allow the entry to reschedule for a later heat, but prior to the next event.

11.2.4 Paddler Safety

All paddlers shall be competent swimmers. Paddlers shall wear US Coast Guard-approved life jackets at all times while in a canoe during competition and/or practice. Wet suit buoyancy pads shall not be used as a substitute for the Coast Guard approved life jacket. Containers or objects not required for canoe operations shall not be permitted in canoes.

11.3 RACE COURSE

11.3.1 General Requirements

The bow of the canoe shall remain the bow of the canoe throughout each race in consideration of a successful negotiation of a turn or finish buoy.

Different colored buoys shall mark the racecourse lanes. The 600-meter Slalom/Endurance and 200-meter Sprint courses must meet the alignment, distance, spacing, and turns as noted in Sections 11.3.2 and 11.3.3, respectively. Figure 11.1 and Figure 11.2 provide recommended course layouts; however, these are subject to site-specific conditions and limitations.

11.3.2 600-meter Slalom/Endurance Course

The slalom/endurance course shall consist of the following subject to site conditions:

- a. A total of 600 meters in distance with a minimum of two (2) turns.
- b. At Conference Competitions the course shall begin with a slalom course consisting of seven (7) buoys. Each slalom buoy shall be staggered 5 meters transversely from each other. Buoys shall be longitudinally spaced at 10 meters with 20 meters between the third and fourth buoy.
- c. At the National Competition the CNCCC reserves the right to modify the location and layout of the slalom portion of the course.

11.3.3 200-meter Sprint Course

A sprint course shall consist of the following subject to site conditions:

- a. Straight course 100 meters out, a 180-degree turn, and 100 meters back.
- b. Lanes shall be no narrower than 15 meters.

11.4 RACE PENALTIES

A canoe's time shall not be considered final until all buoys have been properly negotiated or the corresponding penalty has been assessed as defined below:

- a. A canoe that crosses the finish line in the wrong lane shall be assessed a 30-second time penalty for that particular event.
- b. A canoe that misses one or more slalom buoys may renegotiate the buoy or be assessed a 1-minute time penalty per buoy missed.
- c. A buoy is successfully negotiated when the entire canoe passes on the proper side of the buoy. A canoe may touch a buoy but the top of the buoy must stay above the waterline on the proper side of the canoe until the canoe has entirely passed.
- d. With the exception of the allowance to renegotiate the slalom buoy or accept a time penalty, all other turn buoys must be properly negotiated or the school shall be disqualified for that particular event. Teams must properly negotiate all turn buoys in the endurance race. A sprint turn must be negotiated within the assigned lane.
- e. For a canoe to successfully finish a given race, the bow of the canoe must cross the finish line with the same number of paddlers (in or touching the canoe) with which the race began.
- f. Paddlers shall remain in the boat or touching the boat throughout the race. Safety officials reserve the right to use their best judgment to remove a swamped canoe and paddlers from the racecourse if the situation warrants.

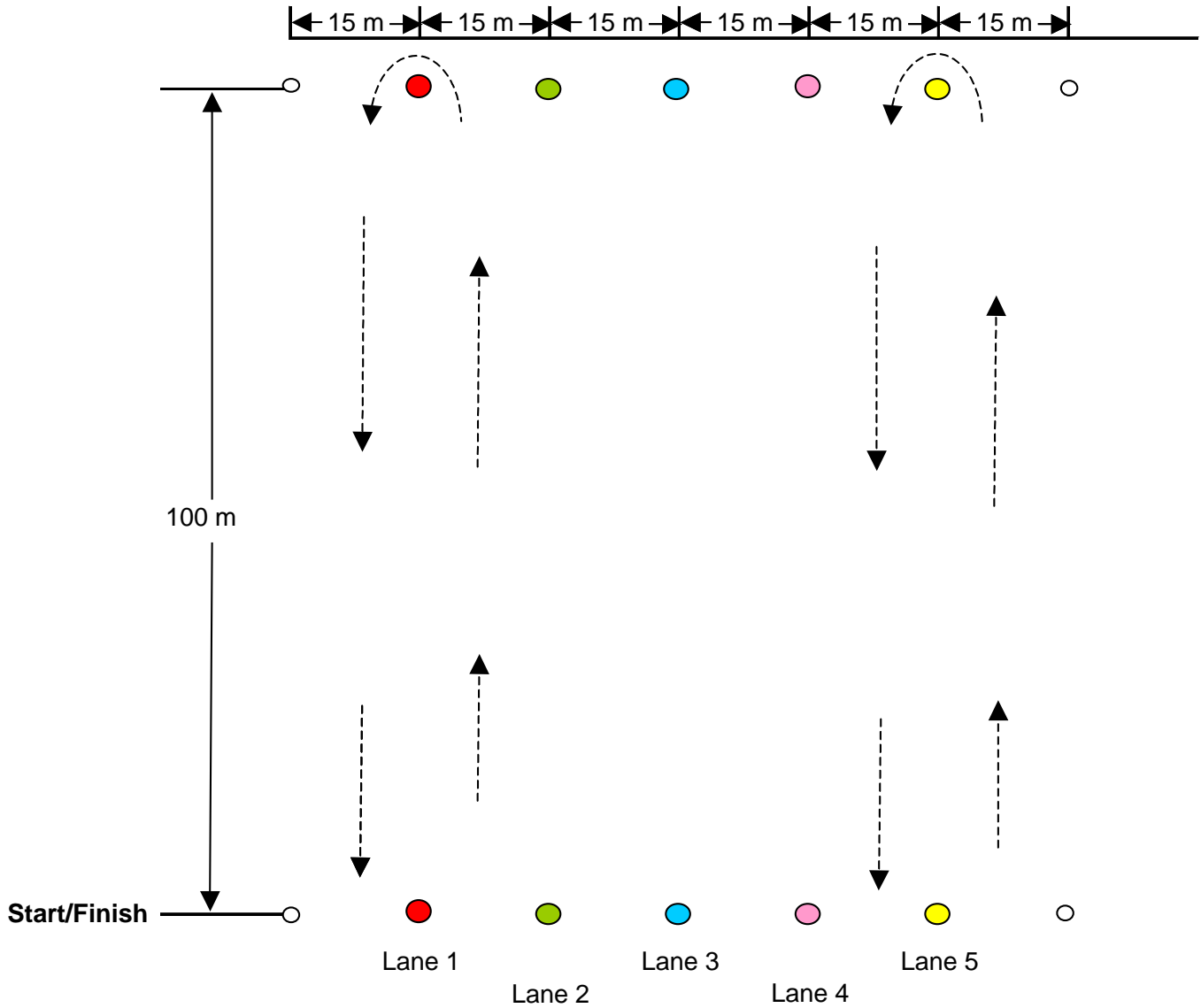

Note: Direction of turn (clockwise or counterclockwise) shall be determined via a coin flip performed during the morning Captain's Meeting and shall be consistent for all heats (preliminary and finals). Figure above depicts that canoes must go up one lane and upon negotiating the turning buoy will go down the lane directly next to it (i.e., a canoe should not finish the race in the same lane it started in).

Figure 11.1 – Sprint Race Course Layout

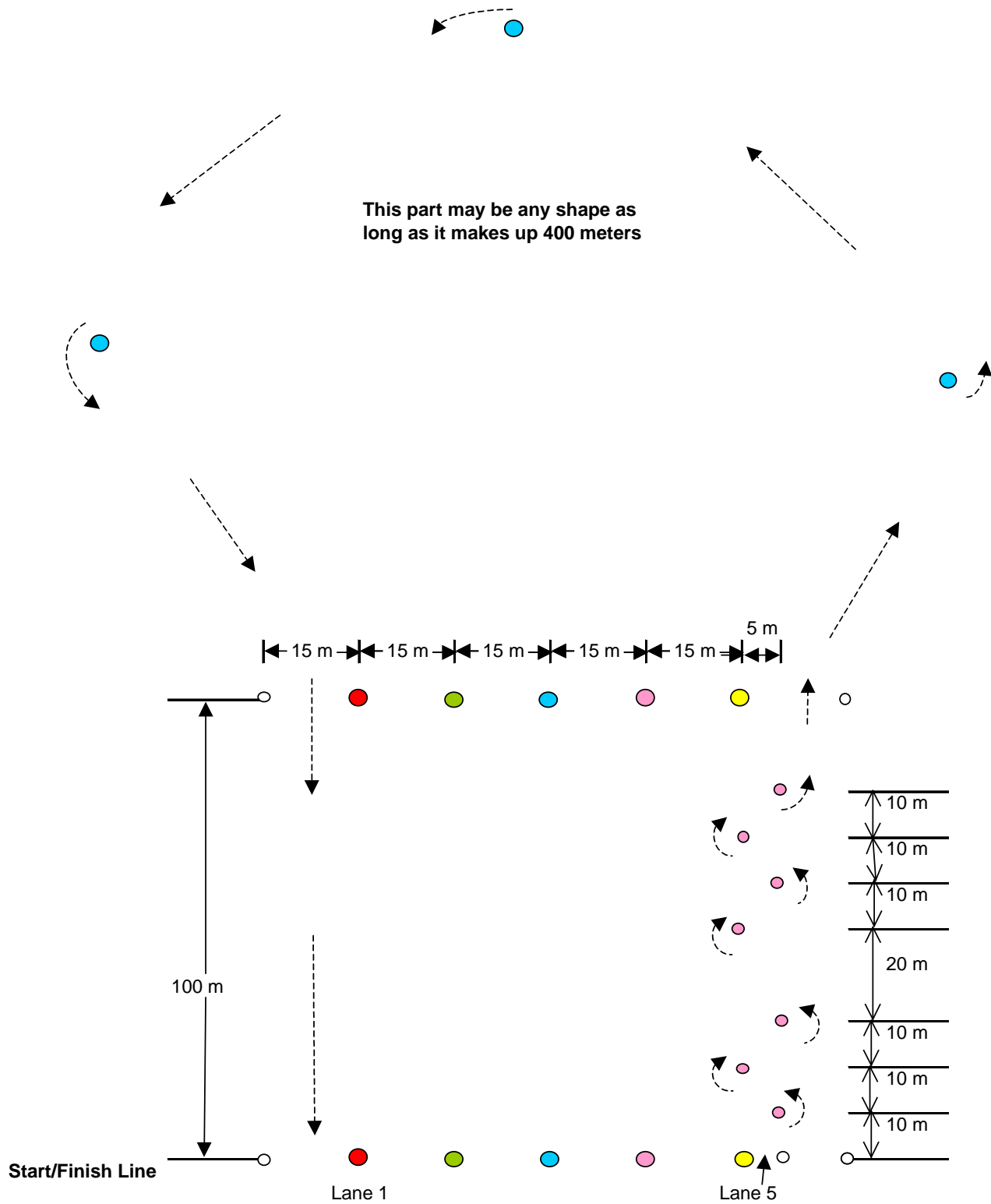

Figure 11.2 – Slalom/Endurance Race Course Layout (Example Layout)

Section 12 – NATIONAL QUALIFYING RULES

12.0 GENERAL

To maintain the competition of the event in addition to creating a more uniform system for national qualification, it shall be mandatory that the Conference Competitions adopt and comply with the following sections applicable to the National Competition:

- a. Section 1 – GENERAL RULES AND ELIGIBILITY REQUIREMENTS; All except Sections 1.3.
- b. Section 2 – CANOE; Section 3 – CONCRETE; Section 4 – REINFORCEMENT; Section 5 – FINISHING; Section 6 – DESIGN PAPER; Section 7 – ENGINEER'S NOTEBOOK; Section 8 – ORAL PRESENTATION; Section 9 – FINAL PRODUCT; Section 10 – FINAL PRODUCT DISPLAY; Section 11 – RACE RULES AND REGULATIONS; and Section 13 – OVERALL SCORING; All.

12.1 APPEAL PROCESS

The Conference Competition judges shall settle all appeals from their competition, decide the Conference Competition winner, and distribute awards based on scores that have been checked and officially ratified by the Conference Head Judge (Section 1.9.1). This is the only formal appeal process available for the Conference Competition.

Section 13.7 covers the appeal process and rule clarification that shall be implemented at the Conference and National Competitions.

The CNCCC will not entertain any appeals filed by the teams after the Conference Competition nor will they overturn any of the judges' decisions.

12.2 ASCE MEMBERSHIP

Concrete Canoe Competition team members at the Conferences shall be members of an ASCE Student Organization affiliated with their university. Registered participants for the National Concrete Canoe Competition™ shall be National Student Members of ASCE and shall provide valid ASCE ID numbers with the submittal of the registration materials. Team members that do not provide valid ASCE ID numbers will not be allowed to participate as registered participants.

Section 13 – OVERALL SCORING

13.0 GENERAL

Scoring for the competition is divided into four (4) events:

Event	Maximum Competition Points
1. Academic Judging - Design Paper	25
2. Academic Judging - Oral Presentations	25
3. Academic Judging - Final Product	25
4. Races (5 races)	25
	100

13.1 COMPETITION POINTS FOR ACADEMIC JUDGING

Competition Points for Design Paper, Oral Presentation and Final Product are awarded per Appendix A – Judges’ Score Sheets. Deductions assessed for Design Paper, Oral Presentation and Final Product are also provided in Appendix A. For the Design Paper, Oral Presentation and Final Product, the event points for a given judge (i.e. raw score) will result in an independent ranking from 1st to nth place (with n being equal to the number of teams competing) for each category. The independent rankings of the judges will then be averaged to determine the overall score for the entry. Raw scores will be used in the event of tiebreaker (Section 13.3).

For example, assume a team receives scores of 90, 87, 94, 83, and 90 for the design paper which when compared to scores given to other teams by the same judges result in independent rankings of 2nd, 3rd, 1st, 2nd, and 4th places, respectively. The average ranking will be 2.4. The average ranking of all teams shall then be compared to determine the overall placement in a given category.

An official electronic scoresheet is available from CNCCC for use by the Conference competitions.

13.1.1 Number of Judges

Each event shall be evaluated by a panel of judges. The minimum number of judges for any given event is three (3) and the maximum is five (5). The head judge must be available for all aspects of the competition and is required to judge each of the events.

The judges for the Conference Competitions are selected by the conference host school (preferably with assistance from the local ASCE Section or Branch). It is the responsibility of the host school for ensuring that an adequate number of judges are available for the various aspects of the competition.

The judges for the National Competition are selected by ASCE. The national panel will be comprised of five (5) judges, one of which is selected from the previous year’s competition to serve as the returning head judge.

13.2 RANKING

Placing for each event shall be determined by the ranking of the overall scores. In the event of a tie, the average of the raw scores will determine the actual placing. In the event that the tie remains after averaging the raw scores, then the tie will remain. Competition points shall be determined by dividing points for the positions

involved in the tie. For example, if a second place tie occurs in the design paper event, points for second and third places will be averaged and awarded to the tied teams, if a tie remains after an after of the raw scores. The team with the next highest score will receive points for fourth place.

13.3 TIEBREAKER (FINAL OVERALL STANDINGS)

Ties in the final standings for the competition overall for first and second places shall be broken. In such cases, a tie breaking score, *TBS*, shall be calculated according to the following formula:

$$TBS = \frac{25}{100} \left(\frac{\sum DPP}{NOJ} \right) + \frac{25}{100} \left(\frac{\sum OPP}{NOJ} \right) + \frac{25}{100} \left(\frac{\sum FPP}{NOJ} \right) + RP$$

where: *DPP* = design paper event points for a given judge (Appendix A-1), *OPP* = oral presentation event points for a given judge (Appendix A-2), *FPP* = final product (aesthetics) event points for a given judge (Appendix A-3), *NOJ* = number of judges, and *RP* = unmodified race points. **No judge's score shall be dropped when calculating these points.** The calculation of the *TBS* shall not change the standings for team placement in any given academic scoring part. Of the teams tied for overall winner or overall second place, the team with the highest *TBS* shall be awarded the place in contention.

If a tie still exists for first and/or second place after the tie breaking scores have been determined, then the judges shall determine the overall winner for the competition position. The judges may choose to base their decision on whatever criteria they deem appropriate including but not limited to their subjective evaluation of determination, dedication, sportsmanship, enthusiasm, and overall comporment. The judges' criteria and decision shall be final and may not be appealed.

13.4 COMPETITION POINTS

Competition points will be allotted per place according to the following table:

Place	Academic Events			Race Events		
	Design Paper	Oral Pres.	Final Product	Slalom/Endurance	Men's & Women's Sprints	Coed Sprints
First	25.0	25.0	25.0	5.0	4.5	6.0
Second	22.5	22.5	22.5	4.5	4.0	5.4
Third	20.0	20.0	20.0	4.0	3.6	4.8
Fourth	17.5	17.5	17.5	3.5	3.1	4.2
Fifth	15.0	15.0	15.0	3.0	2.6	3.6
Sixth	12.5	12.5	12.5	2.5	2.2	3.0
Seventh	10.0	10.0	10.0	2.0	1.8	2.4
Eighth	7.5	7.5	7.5	1.5	1.4	1.8
Ninth	5.0	5.0	5.0	1.0	0.9	1.2
Tenth	2.5	2.5	2.5	0.5	0.4	0.6

13.5 RACES

No points shall be given for the preliminary or qualifying heats unless unforeseen circumstances prevent the running of the final heats or the host school determines before the race competition starts that separate finals heats will not be run. For the slalom/endurance race, no points are awarded a team that does not finish or does not race. For all sprint races, if a team qualifies for a final event but cannot start an event, that team does not receive points and the team's slot is conceded to the team with the next best preliminary sprint time. For final sprint races, if a team starts a race in a canoe deemed race-worthy by the judges, but is unable to complete the race, they are awarded the points corresponding to completing the race last in their final.

13.5.1 No Races Conducted

In the event that none of the race events can take place (for example, bad weather or unsafe racing conditions), the overall competition score shall be based solely on the results of the academic portion of the competition (Design Paper, Oral Presentation, and Final Product) with the maximum possible score being 75 points.

13.5.2 Partial Completion of Races

In the event that all of the race events cannot be conducted/completed, only the scores for all of the completed races (i.e., each school participated in the event) shall be accounted for in the overall competition score. The race scores should not be adjusted in an attempt to account for the races not conducted/completed. For example, if the men and women's endurance/slalom were completed, and the sprints could not be completed, the maximum possible race score is 10 points (instead of the maximum possible score of 25 if all races were held).

13.6 SUMMARY OF DEDUCTIONS / DISQUALIFICATION

13.6.1 General

These deductions may also be referenced in other sections of these rules and regulations and/or the scoring sheets. Moreover, judges may make additional deductions if a situation not covered specifically by the rules arises. **It is highly suggested that the judges contact the CNCCC regarding situations that may not be covered in the rules to determine the appropriate course of action.**

13.6.2 Disqualification

Teams may be disqualified from the competition for the following:

- a. Failure to follow student eligibility requirements (Section 1.2.1).
- b. Violations under the Spirit of the Competition [at the discretion of the CNCCC and/or Judges] (Section 1.8).
- c. Failure to follow academic year, rebuilding, and material requirements (Sections 2 through 5).
- d. Sportsmanship and interference requirements (Sections 11.1.3 and 11.1.4)
- e. Failure to follow safety rules (Sections 11.2).

13.6.3 Standardized Deductions

To ensure fair and consistent judging throughout the Conference and National Competitions, the deductions are standardized (e.g., the point deductions for the various infringements cannot be less than or greater than the number specified) and apply only to the relevant competition event.

The standardized deductions are for items outlined in Section 6 – DESIGN PAPER and are listed on the *Design Paper Deduction Score Card* located in Appendix A-5. The standardized deductions are for items outlined in Section 7 - ORAL PRESENTATION and as prescribed on the *Oral Presentation Scoring Sheet* located in Appendix A-2. The standardized deductions are for items outlined in Section 8 - FINAL PRODUCT and are listed on the *Final Product Deduction Score Card* located in Appendix A-6. Race penalties are outlined in Section 11.4.

13.7 APPEAL OF DEDUCTIONS

During both the Conference and National Competitions, the judges and/or CNCCC shall inform the team captains about the deductions that have been assessed against the canoe and/or team in the various events. The raw scores and standings shall not be provided to the teams, only the deductions being applied. The team captains will then be afforded the opportunity to appeal the deductions through a written response that will then be reviewed by the judges. **Designated team captains are the only individuals that may appeal the deductions.** The decisions of the judges following their review are final and the judges will accept no further appeals beyond those decisions. The judges may contact the CNCCC in order to ensure that the proper deductions are made and for any additional guidance.

The CNCCC will not consider any appeals beyond the Conference Competition, nor will it overturn any of the conference judges' decisions regarding the deductions assessed against a given team.

The following sections detail the process of teams being informed of the deductions, the team captain's appeal (if they choose to do so), and the rendering of the final decision of the judges following their review of the appeal.

13.7.1 Design Paper

Following the scoring of the Design Paper, the judges shall come to a consensus of which deductions as listed on the *Design Paper Deduction Score Card* (Appendix A-5), if any, shall be assessed against a team. On the first day of the competition, the Head Judge or CNCCC member shall provide the team captains a copy of the *Design Paper Deduction Score Card* indicating which deductions, including their point value, are being applied and a *Request for Clarification and Appeals Form* (Appendix B-4 or B-5).

If the team chooses to appeal the deductions, the team captains will have until the date/time specified to submit to the Head Judge or CNCCC member the completed *Design Paper Deduction Score Card* (with signature), *Request for Clarification and Appeals Form* and any supporting documentation. The judges shall review the appeal, render their final decision, and inform the team captains of the decision prior to the completion of the day's events or the Awards Presentation, whichever comes first. Upon being informed of the judges' decision, no further appeal may be filed.

13.7.2 Final Product

13.7.2.1 Aesthetics Judging

Immediately following the aesthetics judging of the team's Final Product, the judges shall come to a consensus of which standardized deductions as listed on the *Final Product Deduction Score Card* (Appendix A-6), if any, shall be assessed against a team. The head judge or CNCCC member shall immediately provide the team captains a *Final Product Deduction Score Card* indicating which deductions, including their point value, are being applied and a *Request for Clarification and Appeals Form* (Appendix B-4 or B-5).

If the team chooses to appeal the deductions, the team captains will have until the date/time specified to submit to the Head Judge or CNCCC member the completed *Final Product Deduction Score Card* (with signature), *Request for Clarification and Appeals Form* and any supporting documentation. The judges shall review the appeal, render their final decision, and inform the team captains of the decision prior to the completion of the day's events or the Awards Presentation, whichever comes first. Upon being informed of the judges' decision, no further appeal may be filed.

13.7.2.2 Durability

Following the completion of the endurance/slalom races and the preliminary sprint races, all of the canoes shall be removed from the water, assembled in a common place, and inspected by the judges and/or CNCCC members for the usage of tape as a repair material. Team captains shall be present with their canoes at the time of inspection and shall have with them any *Damage/Accident Report* (Appendix B-3) including written permission for any tape that is applied to the canoe. Any tape that is applied to the canoe, without written permission, is subject to deduction. Tape used to secure gunwale protective caps/coverings and tape used to secure additional flotation material in order to pass the flotation test does not apply in this instance. The team captain shall be informed verbally if a point deduction is being assessed. The decision of the judges and/or CNCCC members is final and is not subject to appeal.

13.7.3 Race Events

13.7.3.1 Endurance/Slalom

In the event that any penalties (Section 11.4) have been assessed against a team during the Endurance/Slalom race, the head judge or CNCCC member shall immediately inform the team captain of the infraction and its deduction at the completion of the team's race. The team captains may lodge a verbal appeal before the next three (3) canoes finish the race. Following the review of the appeal, the decision of the judges and CNCCC concerning all aspects of the race shall be final.

13.7.3.2 Sprints

In the event that any penalties (Section 11.4) have been assessed against a team during the Sprint race, the head judge or CNCCC member shall immediately inform the team captain of the infraction and its deduction at the completion of the team's heat. The team captains may lodge a verbal appeal before the start of the next heat. Following the review of the appeal, the decision of the judges and CNCCC concerning all aspects of the race shall be final.

Design Paper		25% of Overall Score	
School Name: _____ Canoe Name: _____		Possible Points	Score (whole numbers)
Analysis Modeling (appropriateness of loading cases, applied loads, support conditions, model geometry) (5 points) Analysis (how the modeling was done) (5 points) Conclusions (appropriateness, validity, and importance of goal properties selected) (5 points)		15	
Testing and Development Testing program (tests used for individual materials and composite action and execution and validity of those tests) (5 points) Development (understands relationship between mix component properties and proportions and achieving design goal based on analysis) (5 points) Conclusions (appropriateness, validity, and importance of test results achieved) (10 points)		20	
Project Management & Construction PM Application (effectively understands and communicates CPM) (5 points) Construction Application (construction process and techniques) (5 points) Project Schedule Completeness (per Section 6.2.2.i.) (5 points) Organization Chart Completeness (per Section 6.2.2.h.) (5 points) Design Drawing Clarity (ease of understanding the drawings) and completeness (per Section 6.2.2.j.) (5 points)		25	
Innovation and Sustainability Incorporation of new, innovative ideas and concepts in the development of the canoe design, concrete mixture, construction and other areas of the project (8 points) Incorporation of sustainable practices and materials into the various aspects of design and construction (7 points)		15	
Mixture Proportions Compliance (materials and proportions) and Correct Math (15 points)		15	
Overall Presentation Effective Use of Graphics, Tables and Charts & Quality of Writing (5 points) Conciseness and Clarity (5 points)		10	
Subtotal		100	
Academic Judging - Design Paper Total			

Oral Presentation		25% of Overall Score	
School Name: _____ Canoe Name: _____		Possible Points	Score (whole numbers)
Presenters Preparation Level (8 points) Confidence (4 points) Voice Projection (4 points) Overall Demeanor (4 points)		20	
Presentation Quality Quality of Audio/Visuals (5 points) Content (20 points) Professionalism of Presentation (15 points)		40	
Judges' Questions Expertise in Answers (30 points) Confidence Level (5 points) Conciseness of Answers (5 points)		40	
Comments:			
Subtotal		100	
Deductions: Failure to observe time limit: A 15-point penalty shall be assessed when the official time exceeds 5 minutes 5 seconds (5:05). An additional 15-point deduction shall be assessed for exceeding each additional minute or fraction thereof on the official timer's clock, i.e., 6:00, 7:00, etc. (Section 8.3).			
Sponsorship or commercialism violation: 15 points			
Failure to adhere to live presentation format: No Oral Presentation Points			
Academic Judging - Oral Presentation Total			

School Name _____

FINAL PRODUCT AESTHETICS SCORE CARD

Evaluation Sheet from Judge: _____

Refer to Sections 9.1.2 and 9.1.3 regarding judging criteria and scoring.
 Enter a numeric value (whole numbers) in category and tally the total score.

	Name of School	Canoe Workmanship (0 to 25 Points,)	Exterior and Interior Finish (0 to 25 Points)	Adherence to Design Criteria (0 to 25 Points)	Cross- Section Workmanship (0 to 15 Points)	Product Display (0 to 10 Points)	Total (100 pts. max)
1							
2							
3							
4							
5							
6							
7							
8							
9							
10							
11							
12							
13							
14							
15							
16							
17							
18							
19							
20							
21							
22							
23							
24							
25							

INSTRUCTIONS - DEDUCTION SCORE CARDS

Instructions:

1. The Conference/National Judges shall come to a consensus on the determination of any infractions made by the team regarding the particular competition event (i.e., Design Paper and Final Product.).
2. Judges shall circle the point value of the deduction in the “Deduction” column. The points of the deductions for the infractions are standardized (i.e., cannot be higher or lower than what is prescribed).
3. The Head Judge shall tally the deductions and initial his/her name next to it. At the National Competition, a CNCCC member may tally the deductions in lieu of the Head Judge; however, the judges will make the determination of the infractions.
4. **The total amount of deductions can exceed 100 points.**
5. The Head Judge (or CNCCC member) shall provide all team captains with these forms to inform them of the deductions being assessed against them. Teams with no deductions will also be provided with these forms in order to assure anonymity.
6. The team captains shall indicate if they agree with the infractions and deductions or if they wish to appeal any of the infractions by signing the form. Teams that wish to appeal the infractions shall be given a reasonable amount of time to review the rules, obtain their supportive documentation, and provide the judges with their response. **Teams are strongly cautioned to be able to substantiate their appeals.**
7. The Head Judge (or CNCCC member) shall indicate the day and time (deadline) that the team captains have to submit the completed and signed form to the judges or CNCCC member.
8. Following the receipt of the form, the judges shall re-evaluate any infractions that the teams may appeal given the supportive documentation that they provide, and render their final decision on the form. The Head Judge shall input the official total deduction, sign off on the form, and inform the team captains of the judges’ decision. Once this is done, no further appeals regarding this matter will be entertained.
9. All appeals shall be handled prior to the Awards Ceremony. The final tally shall be inputted on the paper copy of the score sheet and in the electronic score sheet which is then officially ratified by the Head Judge. At the National Competition, the Head Judge and the CNCCC will ratify the scores.
10. Members of the CNCCC will either be on-call (during conference competitions) or on-site (during the national competition) and are available to provide guidance, clarification, and interpretation of the rules and regulations for the judges. During the course of the competitions, teams are given the option to request that the judges contact the CNCCC for rule interpretation (see *Request for Clarifications and Appeals*).

DESIGN PAPER DEDUCTION SCORE CARD

School: _____

Infraction	Deduction <i>(Circle those that apply)</i>
A. Failure to follow format, margin, page and/or body text requirements	10 Points
B. Design Paper over specified number of pages (____ page) x 10 Pts/page	__ Points
C. Design Paper/Engineer's Notebook received after deadline (____ days) x 5 Pts/day <i>(Engineer's Notebook, electronic copy, only applicable at the National Competition)</i>	__ Points
D. Not providing all information required in Executive Summary	5 Points
E. Missing Table of Contents and/or Executive Summary	15 Points
F. Missing (or Incomplete) Appendix A – References	15 Points
G. Missing (or Incomplete) Appendix B – Mixture Proportions	15 Points
H. Missing (or Incomplete) Appendix C – Bill of Materials	15 Points
I. Failure to add <i>Repair Report</i> or <i>Reconstruction Request</i> as Appendix <i>(Only applicable at the National Competition)</i>	15 Points
J. Use of plagiarized material	No Design Paper Points
Total Deductions (Design Paper)	____ Points

Please provide information on the infraction(s) being applied:

Team captains shall have until (day/time) _____ to either agree with the judges' deductions for the infractions listed above or to appeal the decision and provide supportive documentation.

FOR TEAM CAPTAINS ONLY

- We agree with the infractions and deductions applied to the Design Paper.
- We wish to appeal the following infractions: A B C D E F G H I J *(circle those that apply)*

Team Captain

Team Captain

FOR COMPETITION OFFICIAL USE ONLY

Upon review of the Appeal Form (and any supportive documentation) provided by the team captain:

- The deductions originally determined by the judges shall stand.
- The deductions for A B C D E F G H I J *(circle those that apply)* shall be rescinded.

The total deductions for the Design Paper are _____ Points.

Head Judge

FINAL PRODUCT DEDUCTION SCORE CARD

School: _____

Infraction	Deduction <i>(Circle those that apply)</i>
A. A canoe not built within current academic year, cannot race due to design or safety issues, or cannot complete sprint and endurance events	No Final Product Points
B. Reinforcement thickness exceeds 50% of canoe thickness	No Final Product Points
C. Use of Bondo®, epoxy, or similar materials for construction or repairs	No Final Product Points
D. Canoe does not meet dimensional restrictions (length, beam width, height and rocker)	15 Points
E. Non-compliant lettering	5 Points
F. Improper finishing (sealer, paint, stain, etc.)	25 Points
G. Non-compliant hydraulic cement content (exceeds 400 lb/yd ³)	15 Points
H. Non-compliant c/cm ratio (below 0.30 or above 0.50)	15 Points
I. Canoe does not meet unit weight (55-70 lb/ft ³) requirements	15 Points
J. Missing one or more items from Product Display or Notebook (Notebook, display, samples of concrete, aggregate, etc.) or additional photographs on cross section	25 Points
K. Failure of reinforcement to meet required Percent Open Area	15 Points
L. Cross-section not meeting specifications (size) and/or does not properly represent the canoe	20 Points
M. Reported weight of canoe is not within ± 10 lbs. of the measured weight (<i>NCCC only</i>)	10 Points
N. School granted permission to repair (25 points) or reconstruct (50 points) canoe (<i>NCCC only</i>)	___ Points
Total Deductions (Final Product)	___ Points

Team captains shall have until (day/time) _____ to either agree with the judges' deductions for the infractions listed above or to appeal the decision and provide supportive documentation.

FOR TEAM CAPTAINS ONLY

- We agree with the infractions and deductions applied to the Final Product.
- We wish to appeal the following infractions: A B C D E F G H I J K L M N (*circle those that apply*)

Team Captain

Team Captain

FOR COMPETITION OFFICIAL USE ONLY

Upon review of the Appeal Form (and any supportive documentation) provided by the team captain:

- The deductions originally determined by the judges shall stand.
- The deductions for A B C D E F G H I J K L M N (*circle those that apply*) shall be rescinded.

Flotation Test PASS / FAIL (if FAIL, deduct 25 points).

Durability: NO TAPE / TAPE (if TAPE is needed for durability-related issues, deduct 25 points)

The total deductions for the Final Product are _____ Points.

Head Judge

REPAIR PROCEDURE REPORT

School Name: _____

Canoe Name: _____

Team Captain(s): _____

Date of Request: _____

Description of Cause:

Description of Repair:

Materials used in Repair:

Description of Supporting Documentation:

Provide a list of Supporting Documentation attached to this report

CNCCC Disposition		
Date:		
Request to Repair Canoe:	<input type="checkbox"/> Granted	<input type="checkbox"/> Declined
Reason for Disposition:		

This report, CNCCC disposition, and supporting documentation shall be included in Appendix D of the Design Paper. Failure to do so will result in a 25-point deduction from the Design Paper final score.

Filing this report does not guarantee the school will be granted permission to conduct repairs to their canoe. The ability to do so is a function of the reason for the request and the supporting documentation. Under no circumstances should a school consider a verbal disposition permission to repair their canoe.

If the school is permitted to conduct repairs, that school will receive a 25-point penalty for doing so. The maximum final product points will be reduced to 75 out of 100 points. This penalty may be waived at the discretion of the CNCCC on a case by case basis.

RECONSTRUCTION REQUEST

School Name: _____

Canoe Name: _____

Team Captain(s): _____

Date of Request: _____

Reason for Request:

Description of Supporting Documentation:

Provide a list of Supporting Documentation attached to this request

CNCCC Disposition	
Date:	
Reconstruction Request:	<input type="checkbox"/> Granted <input type="checkbox"/> Declined
Reason for Disposition:	

This request, CNCCC disposition, and supporting documentation shall be included in Appendix D of the Design Paper. Failure to do so will result in a 25-point deduction from the Design Paper final score.

Filing this report does not guarantee the school listed above will be granted a Reconstruction Request. The ability to do so is a function of the reason for the request and the supporting documentation. Under no circumstances should a school consider a verbal disposition permission to rebuild their canoe.

If the school is permitted to reconstruct, that school will receive a 50-point penalty for doing so. The maximum final product points will be reduced to 50 out of 100 points. This penalty may be waived at the discretion of the CNCCC on a case by case basis.

DAMAGE/ACCIDENT REPORT

School Name: _____

Name of Canoe: _____

Date of Accident: _____

Location of Accident: _____

Type of Accident:

- Collision with other canoe Paddler fell out of canoe
 Collision with inanimate object Other: _____

Briefly Describe Circumstances of Accident:

Describe in Detail the Extent of Damage:

Team Captain's Signature: _____

Team Captain's Signature: _____

FOR COMPETITION OFFICIAL USE ONLY

Damage is due to accident outside the control of the paddlers? (Circle one) YES NO

Comments:

Deduct 25 points from Final Product _____ Do Not Deduct 25 Points from Final Product _____

Head Judge: _____

REQUEST FOR CLARIFICATION AND APPEALS

(CONFERENCE COMPETITIONS)

Instructions: Completed forms must be submitted immediately by the Team Captain to the Conference Concrete Canoe Competition Head Judge. Requests for clarification and appeals will not be considered once the competition has concluded. All decisions of the judges are final.

School Name: _____

Team Captain(s): _____

Nature of Inquiry

- () Design Paper
- () Oral Presentation
- () Final Product
- () Races
- () Other: _____

Briefly Describe Nature of Inquiry or Appeal: (Continue on reverse side if more space is needed).

SAMPLE
Not For Official Use

- We formally request that the CNCCC member on-call be contacted in order to obtain an official interpretation or clarification regarding this matter.*

Rules & Regulations Section(s) Referenced: _____

Team Captain Signature: _____

Team Captain Signature: _____

REQUEST FOR CLARIFICATION AND APPEALS

(ASCE NATIONAL COMPETITION)

Instructions: Completed forms must be submitted immediately by the Team Captain to the Committee on National Concrete Canoe Competitions (CNCCC). Requests for clarification and appeals will not be considered once the competition has concluded. All decisions are final.

School Name: _____

Team Captain(s): _____

Nature of Inquiry

- () Design Paper
- () Oral Presentation
- () Final Product
- () Races
- () Other: _____

Briefly Describe Nature of Inquiry or Appeal: (Continue on reverse side if more space is needed).

SAMPLE
Not For Official Use

Rules & Regulations Section(s) Referenced: _____

Team Captain Signature: _____

Team Captain Signature: _____

General Guidelines for Concrete Mixture Data Table 3.1

References

Section 3 – CONCRETE	2011 NCCC Rules and Regulations
ASTM C 138/C 138 M	Standard Test Method for Density (Unit Weight), Yield and Air Content (Gravimetric) of Concrete

This appendix provides some general guidelines and helpful hints so that teams understand what is required in the table and how it can be properly filled out. The table is broken down into three (3) major categories: *Oven-dry (Non-SSD) Proportions as Designed*, *Actual Batched Proportions* and *Yielded Proportions*. Each of these categories are then broken down into “Amount” and “Volume”

General Comments

- Under the categories of “Cementitious Materials,” “Aggregates,” “Fibers,” and “Admixtures”, provide the name of the particular constituents that are being used. Generic or commercial (trade) names may be used as long as it is clear what the product is.
- Absorption values (in percent) for the aggregates shall be provided (one or two decimal places).
- Under the “Specific Gravity” column, provide the specific gravity (dimensionless) of the cementitious materials, aggregates, fibers, and water used in the concrete mix. Two decimal places are sufficient.
- The density of the admixtures shall be provided in *lb/gal*.

Non-SSD Proportions as Designed – This category contains the design proportions which are developed prior to going to the laboratory and batching the concrete. The proportioning may be based on previous mixtures (research and/or experience), ACI guides, recommendations from a supplier, etc. In this process, some parameters are assumed such as desired slump and air content. This is your starting point in the mixture proportioning process – determining what you think you need to make your concrete mix. It is more of putting pen to paper rather than actually mixing materials. In the end, the proportions provided in this category make up 1 cubic yard (27 cubic feet) of concrete (proportions are “X” lbs per 1 cubic yard).

Actual Batched Proportions – This category indicates what is batched in the laboratory and includes any deviations from proposed proportions (Non-SSD Proportions) or assumed amounts. Using the proportions listed in the Non-SSD proportions and a given batch size, the amount of the various materials needed are computed. Once the concrete is batched and mixed, the plastic (wet) unit weight of the concrete is determined from the cylinders, cubes and/or beams taken.

Yielded Proportions – This category is to report the true amount of each ingredient of the concrete mixture, taking into account the actual batched amounts. Given that the measured plastic (wet) unit weight of concrete will most likely not be exactly what was designed (Non-SSD), minor adjustments need to be made to the designed proportions. The ratio between the actual yield and design yield (or actual unit weight and design unit weight) is the “relative yield” (Ry). The relative yield is then used in the computations to adjust the design proportions so that they become the final yielded proportions.

The following is a step-by-step computation for designing a concrete mixture proportion, the batching of concrete in the laboratory (including the determination of the yield) and the computation of the yielded proportions. Specific gravities (SG) of the various materials are indicated in the completed tables.

Material	Non-SSD Amounts (amounts per 1 cy of concrete)
Type III Cement	360 lbs
Fly Ash (Class C)	340 lbs
Blast Furnace Slag	100 lbs
Fibers	PVA 5.0 lbs; Nylon 2.0 lbs
Aggregates:	A: 200 lbs (dry); Absorption 20%
	B: 200 lbs (dry); Absorption 8%
	C: 100 lbs (dry); Absorption 5%
w/cm ratio	0.375
Admixtures:	8 fl oz/cwt HRWR Admixture (40% solids by weight, 8.5 lb/gal)
	200 fl oz/cwt Latex (60% solids by weight, 8.8 lb/gal)
	20 fl oz/cwt Liquid Dye (50% solids by weight, 10.0 lb/gal)

Absolute Volume Method

The absolute volume of a given material is computed by dividing the mass of the material by the absolute density, which is the specific gravity (G_s) times the density of water (62.4 pcf) as shown by:

$$\text{Absolute Volume} = \text{mass} / (G_s \times 62.4)$$

Example: How much volume does 360 lbs of portland cement occupy knowing that $G_s = 3.15$?

Solution:

$$\begin{aligned} \text{Volume}_{\text{cement}} &= \text{Weight}_{\text{cement}} / (G_{s(\text{cement})} \times 62.4) \\ &= 360 / (3.15 \times 62.4) = \mathbf{1.832 \text{ cy}} \end{aligned}$$

In a batch of concrete, the sum of the absolute volumes of cementitious materials, aggregate, fibers, water, and air, gives the volume of concrete produced per batch. The above equation can be used to determine the volumes of the various constituents and populate the table.

Water

Based on the assumed w/cm ratio, the amount of water anticipated can be simply computed using the total amount of cementitious material in the mixture

$$\text{Water} = w/cm \times cm$$

Example: How much water is needed for 800 lbs of cm using a w/cm of 0.375?

Solution:

$$\begin{aligned} \text{Water} &= w/cm \times cm \\ \text{Water} &= 0.375 \times 800 \text{ lbs} = \mathbf{300 \text{ lbs}} \end{aligned}$$

The water that is computed from the w/cm ratio is the water that is needed to hydrate the cementitious materials (cm). The water for cm hydration basically comes from two sources – water from the admixtures and additional batch water.

$$\text{Water for CM Hydration} = \text{Water from Admixtures} + \text{Additional Water}$$

The water for cm hydration does not account for the water this is needed to bring the aggregate to the Saturated Surface Dry (SSD) condition. The water for the aggregate (SSD) is computed as follows

$$\text{Water for aggregate absorption} = \Sigma (\text{Absorption} \times \text{Amount of Aggregate})$$

The total water in the concrete mixture is the water needed for cm hydration and the water needed for aggregate absorption. The amount of total water (mass, weight) is the sum of the two. Since the aggregate is assumed to be in the dry state in the table, the volume of water for aggregate absorption is already accounted for in the volume of the aggregate. Therefore, the volume of total water is just the volume of the water needed for cm hydration

$$\text{Total Water Amount} = \text{Amount (Water for CM Hydration)} + \text{Amount (Water for Aggregate, SSD)}$$

$$\text{Total Water Volume} = \text{Volume (Water for CM Hydration)}$$

Example : Compute water amounts from admixtures, additional batch water, and water needed to bring the aggregates to the saturated, surface dry condition

Solution:

$$\text{Water in admixture} = \text{dosage} \times \text{cwt of cm} \times \text{water content} \times (1 \text{ gal}/128 \text{ fl oz}) \times (\text{lbs}/\text{gal of admixture})$$

$$\text{Water in latex} = \text{dosage} \times \text{cwt of cm} \times \text{water content} \times (1 \text{ gal}/128 \text{ fl oz}) \times (\text{lbs}/\text{gal of admixture})$$

$$[(200 \text{ fl oz}/\text{cwt}) \times (800 \text{ pcy})/100] \times [(100\% - 60\% \text{ solids})/100] \times (1 \text{ gal}/128 \text{ fl oz}) \times (8.8 \text{ lbs}/1 \text{ gal})$$

$$1600 \text{ fl oz} \times 0.40 \times 8.8/128 = \underline{\underline{44.0 \text{ lbs water from latex admixture /1 cy of concrete}}}$$

$$\text{Water in dye} = \text{dosage} \times \text{cwt of cm} \times \text{water content} \times (1 \text{ gal}/128 \text{ fl oz}) \times (\text{lbs}/\text{gal of admixture})$$

$$[(20 \text{ fl oz}/\text{cwt}) \times (800 \text{ pcy})/100] \times [(100\% - 50\% \text{ solids})/100] \times (1 \text{ gal}/128 \text{ fl oz}) \times (10 \text{ lbs}/1 \text{ gal})$$

$$160 \text{ fl oz} \times 0.50 \times 10/128 = \underline{\underline{6.25 \text{ lbs water from liquid dye /1 cy of concrete}}}$$

$$\text{Water in HRWR} = \text{dosage} \times \text{cwt of cm} \times \text{water content} \times (1 \text{ gal}/128 \text{ fl oz}) \times (\text{lbs}/\text{gal of admixture})$$

$$[(8 \text{ fl oz}/\text{cwt}) \times (800 \text{ pcy})/100] \times [(100\% - 40\% \text{ solids})/100] \times (1 \text{ gal}/128 \text{ fl oz}) \times (8.5 \text{ lbs}/1 \text{ gal})$$

$$64 \text{ fl oz} \times 0.60 \times 8.5/128 = \underline{\underline{2.55 \text{ lbs water from HRWR admixture /1 cy of concrete}}}$$

$$\text{Total water from Admixtures is then } 44 + 6.25 + 2.55 = \underline{\underline{52.80 \text{ pcy of water}}}$$

Water for CM Hydration = Water from Admixtures + Additional Water

Additional Water = Water for CM Hydration - Water from Admixtures

$$\text{Additional Water} = 300 \text{ lbs} - 52.80 \text{ lbs} = \underline{\underline{247.20 \text{ lbs}}}$$

Water for aggregate absorption = Σ (Absorption x Amount of Aggregate)

$$\text{Water for Aggregate Absorption} = (200 \text{ lbs})(20\%) + (200 \text{ lbs})(8\%) + (100 \text{ lbs})(5\%) = \underline{\underline{61 \text{ lbs}}}$$

Total Water Amount = Amount (Water for CM Hydration) + Amount (Water for Aggregate, SSD)

$$\text{Total Water Amount} = 300 \text{ lbs} + 61 \text{ lbs} = \underline{\underline{361 \text{ lbs}}}$$

$$\text{Total Water Volume} = \text{Volume (Water for CM Hydration)} = 300 / 62.4 = \underline{\underline{4.808 \text{ cy}}}$$

Solids

Typically, the proportional volume of the solids included in the admixture is so small in relation to the size of the batch that it can be neglected. The exclusion to this include latex admixtures and dyes (both liquid and in powder form) which can have substantial volumes. **For the purpose of the competition, only latex and dyes solids are to be accounted for.** Disregard the contribution of solids from other admixtures.

The solids content can be computed in a fashion similar to the water content from admixtures

$$\text{Solids in admixture} = \text{dosage} \times \text{cwt of cm} \times \text{solid content} \times (1 \text{ gal}/128 \text{ fl oz}) \times (\text{lbs}/\text{gal of admixture})$$

Example – Based on a dosage of 200 fl oz/cwt for latex, what is the solids content of latex added per cy of concrete, *Note:* 1 gal = 0.13368 cf

Solution:

$$\text{Solids in admixture} = \text{dosage} \times \text{cwt of cm} \times \text{solid content} \times (1 \text{ gal}/128 \text{ fl oz}) \times (\text{lbs}/\text{gal of admixture})$$

$$[(200 \text{ fl oz}/\text{cwt}) \times (800 \text{ pcy})/100] \times [(60\% \text{ solids})/100] \times (1 \text{ gal}/128 \text{ fl oz}) \times (8.8 \text{ lbs}/1 \text{ gal})$$

$$1600 \text{ fl oz} \times 0.60 \times 8.8/128 = \underline{\underline{66.0 \text{ lbs solids from latex admixture /1 cy of concrete}}}$$

If the latex is 40% water by weight, the weight of water is 3.52 lbs (0.40 x 8.8 lbs) and the weight of the solids is 5.28 lbs (in a gal of admixture). Given that the G_s of water equals 1, the volume of water can be determined (3.52 / 62.4) to obtain 0.05641 cf. Therefore the solids volume is 0.07727 cf. The unit weight of solids is then 5.28 lbs / 0.07727 cf = 68.33 pcf and therefore its G_s is determined to be 1.095.

$$\text{Volume}_{\text{solids}} = \text{Weight}_{\text{solids}} / (G_{s(\text{solids})} \times 62.4)$$

$$= 66 / (1.095 \times 62.4) = \underline{\underline{0.966 \text{ cy}}}$$

Mixture ID:				Design Proportions (Non SSD)		Actual Batched Proportions		Yielded Proportions		
Y _D	Design Batch Size (ft ³):									
Cementitious Materials				SG	Amount (lb/yd ³)	Volume (ft ³)	Amount (lb)	Volume (ft ³)	Amount (lb/yd ³)	Volume (ft ³)
CM1	Portland Cement			3.15	360.00	1.832				
CM2	Class C Fly Ash			2.55	340.00	2.137				
CM3	Blast Furnace Slag			2.69	100.00	0.596				
Total Cementitious Materials:					800.00	4.564				
Fibers										
F1	PVA Fibers			1.10	5.00	0.073				
F2	Nylon Fiber			1.30	2.00	0.025				
Total Fibers:					7.00	0.097				
Aggregates										
A1	Aggregate A	Abs:	20	0.45	200.00	7.123				
A2	Aggregate B	Abs:	8	0.90	200.00	3.561				
A3	Aggregate C	Abs:	5	1.70	100.00	0.943				
Total Aggregates:					500.00	11.626				
Water										
W1	Water for CM Hydration (W1a + W1b)				300.00	4.808				
	W1a. Water from Admixtures			1.00	52.80					
	W1b. Additional Water				247.20					
W2	Water for Aggregates, SSD			1.00	61.00					
Total Water (W1 + W2):					361.00	4.808				
Solids Content of Latex Admixtures and Dyes										
S1	Latex			1.10	66.00	0.966				
S2	Liquid Dye			1.50	6.25	0.067				
Total Solids of Admixtures:					72.25	1.03				
Admixtures (including Pigments in Liquid Form)				% Solids	Dosage (fl oz/cwt)	Water in Admixture (lb/yd ³)	Amount (fl oz)	Water in Admixture (lb)	Dosage (fl oz/cwt)	Water in Admixture (lb/yd ³)
Ad1	Latex	8.8	lb/gal	60.00	200.00	44.000				
Ad2	Liquid Dye	10.0	lb/gal	50.00	20.00	6.250				
Ad3	HRWR	8.5	lb/gal	40.00	8.00	2.550				
Water from Admixtures (W1a):						52.80				
Cement-Cementitious Materials Ratio										
Water-Cementitious Materials Ratio										
Slump, Slump Flow, in.										
M	Mass of Concrete, lbs									
V	Absolute Volume of Concrete, ft ³									
T	Theoretical Density, lb/ft ³ = (M/V)									
D	Design Density, lb/ft ³ = (M/27)									
D	Measured Density, lb/ft ³									
A	Air Content, % = [(T - D) / T x 100%]									
Y	Yield, ft ³ = (M/D)									
Ry	Relative Yield = (Y / Y _D)									

With the table populated with the amounts and volumes, the rest of the table can be filled in.

Cement-Cementitious Materials Ratio

The c/cm ratio is a calculated value: $360 \text{ lbs cement} / 800 \text{ lbs cm} = \underline{0.45}$

Water-Cementitious Materials Ratio – The w/cm ratio was assumed and used to determine the amount of water needed based on cm content (in this example, it was 0.375).

Slump – Slump is an assumed value (perhaps based on experience or other design guidance that you have). Generally, you would provide a range of acceptable slump rather than just a hard number. In our example, we are going with a slump of $4 \pm 1 \text{ inch}$.

Mass of Concrete (M) – The mass of concrete is the sum of all of the constituents in the mixture – cm, fiber, aggregate, water and admixture solids.

$$M = \text{Amount}_{cm} + \text{Amount}_{fibers} + \text{Amount}_{aggregate} + \text{Amount}_{water} + \text{Amount}_{solids}$$

$$M = 800 + 7 + 500 + 361 + 72.25 = \underline{1740.25 \text{ lbs}}$$

Absolute Volume of Concrete (V) – The absolute volume of concrete is the sum of all of the constituents in the mixture, noting that the volume of water for aggregate absorption does not need to be accounted for.

$$V = \text{Volume}_{cm} + \text{Volume}_{fibers} + \text{Volume}_{aggregate} + \text{Volume}_{water} + \text{Volume}_{solids}$$

$$V = 4.564 + 0.097 + 11.626 + 4.808 + 1.033 = \underline{22.128 \text{ cf}}$$

Note that this value has to be less than 27 cf (1 cy)

Theoretical Density (T) – is the density of concrete with no air in it and is the mass of concrete (M) divided by the absolute volume of concrete (V)

$$T = M / V$$

$$T = 1740.25 \text{ lb} / 22.128 \text{ cf} = \underline{78.64 \text{ pcf}}$$

Design Density (D) – is the density of concrete with air in it and is the mass of concrete (M) divided by 27

$$D = M / 27$$

$$T = 1740.25 \text{ lb} / 27 \text{ cf} = \underline{64.45 \text{ pcf}}$$

Air Content – The air content is computed by comparing the theoretical density (no air) to the design density (with air)

$$\text{Air content} = (T - D)/T \times 100$$

$$\text{Air content} = (78.64 - 64.45)/78.64 \times 100 = \underline{\mathbf{18.04\%}}$$

The value of the air content can be checked using the absolute volume method as the volume of air can be computed by subtracting the absolute volume of concrete from 27.

$$\text{Air content} = (27 - V)/27 \times 100$$

$$\text{Air content} = (27 - 22.128)/27 \times 100 = 4.872/27 \times 100 = \underline{\mathbf{18.04\% (check)}}$$

Yield (Y) – The yield is the amount of concrete that is being made. Given that you are making proportions to develop 1 cy of concrete (all of the proportions are in lbs per yard), **the yield must equal 27**. To check, the yield is equal to the mass of concrete (M) divided by the design density (D)

$$Y = M / D$$

$$Y = 1740.25 \text{ lbs} / 64.45 \text{ pcf} = 27 \text{ cf}$$

Mixture ID:				Design Proportions (Non SSD)		Actual Batched Proportions		Yielded Proportions		
Y _D	Design Batch Size (ft ³):									
Cementitious Materials				SG	Amount (lb/yd ³)	Volume (ft ³)	Amount (lb)	Volume (ft ³)	Amount (lb/yd ³)	Volume (ft ³)
CM1	Portland Cement			3.15	360.00	1.832				
CM2	Class C Fly Ash			2.55	340.00	2.137				
CM3	Blast Furnace Slag			2.69	100.00	0.596				
Total Cementitious Materials:					800.00	4.564				
Fibers										
F1	PVA Fibers			1.10	5.00	0.073				
F2	Nylon Fiber			1.30	2.00	0.025				
Total Fibers:					7.00	0.097				
Aggregates										
A1	Aggregate A	Abs:	20	0.45	200.00	7.123				
A2	Aggregate B	Abs:	8	0.90	200.00	3.561				
A3	Aggregate C	Abs:	5	1.70	100.00	0.943				
Total Aggregates:					500.00	11.626				
Water										
W1	Water for CM Hydration (W1a + W1b)				300.00	4.808				
	W1a. Water from Admixtures			1.00	52.80					
	W1b. Additional Water				247.20					
W2	Water for Aggregates, SSD			1.00	61.00					
Total Water (W1 + W2):					361.00	4.808				
Solids Content of Latex Admixtures and Dyes										
S1	Latex			1.10	66.00	0.966				
S2	Liquid Dye			1.50	6.25	0.067				
Total Solids of Admixtures:					72.25	1.03				
Admixtures (including Pigments in Liquid Form)				% Solids	Dosage (fl oz/cw t)	Water in Admixture (lb/yd ³)	Amount (fl oz)	Water in Admixture (lb)	Dosage (fl oz/cw t)	Water in Admixture (lb/yd ³)
Ad1	Latex	8.8	lb/gal	60.00	200.00	44.000				
Ad2	Liquid Dye	10.0	lb/gal	50.00	20.00	6.250				
Ad3	HRWR	8.5	lb/gal	40.00	8.00	2.550				
Water from Admixtures (W1a):						52.80				
Cement-Cementitious Materials Ratio					0.450					
Water-Cementitious Materials Ratio					0.375					
Slump, Slump Flow, in.					4 +/1 in.					
M	Mass of Concrete, lbs				1740.25					
V	Absolute Volume of Concrete, ft ³				22.128					
T	Theoretical Density, lb/ft ³ = (M/V)				78.64					
D	Design Density, lb/ft ³ = (M/27)				64.45					
D	Measured Density, lb/ft ³									
A	Air Content, % = [(T - D) / T x 100%]				18.04					
Y	Yield, ft ³ = (M/D)				27					
Ry	Relative Yield = (Y / Y _D)									

Now that the Non-SSD Proportions as designed has been completed, batch the proportions in the laboratory so that specimens can be made to determine the true unit weight, air content, workability and compressive/tensile strengths, etc.

Determine the batched proportions for a 1 ft³ batch of concrete, based on the Non-SSD proportions.

Mixture ID:				Design Proportions (Non SSD)		Actual Batched Proportions		Yielded Proportions		
Y _D	Design Batch Size (ft ³):		1							
Cementitious Materials				SG	Amount (lb/yd ³)	Volume (ft ³)	Amount (lb)	Volume (ft ³)	Amount (lb/yd ³)	Volume (ft ³)
CM1	Portland Cement		3.15	360.00	1.832	13.33	0.068			
CM2	Class C Fly Ash		2.55	340.00	2.137	12.59	0.079			
CM3	Blast Furnace Slag		2.69	100.00	0.596	3.70	0.022			
Total Cementitious Materials:				800.00	4.564	29.63	0.17			
Fibers										
F1	PVA Fibers		1.10	5.00	0.073	0.19	0.003			
F2	Nylon Fiber		1.30	2.00	0.025	0.07	0.001			
Total Fibers:				7.00	0.097	0.259	0.004			
Aggregates										
A1	Aggregate A	Abs: 20	0.45	200.00	7.123	7.41	0.264			
A2	Aggregate B	Abs: 8	0.90	200.00	3.561	7.41	0.132			
A3	Aggregate C	Abs: 5	1.70	100.00	0.943	3.70	0.035			
Total Aggregates:				500.00	11.626	18.52	0.431			
Water										
W1	Water for CM Hydration (W1a + W1b)			300.00	4.808	11.11	0.178			
	W1a. Water from Admixtures		1.00	52.80		1.96				
	W1b. Additional Water			247.20		9.16				
W2	Water for Aggregates, SSD		1.00	61.00		2.26				
Total Water (W1 + W2):				361.00	4.808	13.37	0.18			
Solids Content of Latex Admixtures and Dyes										
S1	Latex		1.10	66.00	0.966	2.44	0.036			
S2	Liquid Dye		1.50	6.25	0.067	0.23	0.002			
Total Solids of Admixtures:				72.25	1.03	2.68	0.04			
Admixtures (including Pigments in Liquid Form)				% Solids	Dosage (fl oz/cw t)	Water in Admixture (lb/yd ³)	Amount (fl oz)	Water in Admixture (lb)	Dosage (fl oz/cw t)	Water in Admixture (lb/yd ³)
Ad1	Latex	8.8 lb/gal	60.00	200.00	44.000	59.26	1.630			
Ad2	Liquid Dye	10.0 lb/gal	50.00	20.00	6.250	5.93	0.231			
Ad3	HRWR	8.5 lb/gal	40.00	8.00	2.550	2.37	0.094			
Water from Admixtures (W1a):					52.80		1.96			

The above table is based on batching 1.0 ft³ and is computed simply by dividing the amounts by 27. It should be noted that when you are actually batching, you may end up adding or subtracting materials from the design (e.g., you added more cm or did not add all of the water). In that case, amend the table to indicate what was batched.

Under “Admixtures”, the Amount is given as *fl oz* which is different than the dosage which is given in *fl oz/cwt* [fluid ounces for every hundred pounds (hundredweight; cwt) of cementitious material]. Therefore, a dosage of 200 fl oz/cwt of latex would result in

$$200 \text{ fl oz/cwt} \times 8 \text{ cwt} = 1600 \text{ fl oz of latex (for a cubic yard of concrete)}$$

Given a batch size of 1 cubic foot, **59.26 fl oz** (1600/27) is added to the batch.

The equations used in the determination of mass of concrete, absolute volume, etc. are again applicable to the batched amounts.

Once you have made your mixtures in the laboratory, you will determine (measure) the plastic (wet) unit weight of the concrete. The plastic unit weight is when you make your QC test cylinders; not after they harden, not after they dry out. That value should be reported in the table. In our example, a concrete with a unit weight of 65.6 pcf was determined and are reporting a slump of 2.5 inches.

You will notice that the “as batched” unit weight (65.6 pcf) is more than the “as designed” unit weight (64.45 pcf). In some cases it may be lower, but generally, it will not be exact. Since there is a difference (and in this example the mass or weights of the constituents did not change), there **MUST** be a change in the amount of air in the mixture.

Compute New Air Content, Yield and Relative Yield of Batched Concrete Mixture

Air Content – The air content is computed by comparing the theoretical density (no air) to the measured density

$$\text{Air content} = (T - D)/T \times 100$$

$$\text{Air content} = (78.64 - 65.6)/78.64 \times 100 = \underline{\underline{16.59\%}}$$

Yield (Y) – The yield is the amount of concrete that was made. The yield of the batch is equal to the mass of concrete (M) divided by the measured density (D)

$$Y = M / D$$

$$Y = 64.45 \text{ lbs} / 65.6 \text{ pcf} = \underline{\underline{0.983 \text{ cf}}}$$

Relative Yield (Ry) – is the ratio of the actual volume of concrete obtained to the volume as designed for the batch calculated as follows:

$$Ry = Y/Yd$$

A value for *Ry* greater than 1.00 indicates an excess of concrete being produced whereas a value less than this indicates the batch to be “short” of its designed volume. In our example, the design yield (*Yd*) is 1 ft³ and the actual yield (*Y*) was 0.983 ft³. Therefore the *Ry* is 0.983 (a “shortage” of concrete).

Mixture ID:				Design Proportions (Non SSD)		Actual Batched Proportions		Yielded Proportions		
Y _D	Design Batch Size (ft ³):		1							
Cementitious Materials				SG	Amount (lb/yd ³)	Volume (ft ³)	Amount (lb)	Volume (ft ³)	Amount (lb/yd ³)	Volume (ft ³)
CM1	Portland Cement		3.15	360.00	1.832	13.33	0.068			
CM2	Class C Fly Ash		2.55	340.00	2.137	12.59	0.079			
CM3	Blast Furnace Slag		2.69	100.00	0.596	3.70	0.022			
Total Cementitious Materials:				800.00	4.564	29.63	0.17			
Fibers										
F1	PVA Fibers		1.10	5.00	0.073	0.19	0.003			
F2	Nylon Fiber		1.30	2.00	0.025	0.07	0.001			
Total Fibers:				7.00	0.097	0.259	0.004			
Aggregates										
A1	Aggregate A	Abs: 20	0.45	200.00	7.123	7.41	0.264			
A2	Aggregate B	Abs: 8	0.90	200.00	3.561	7.41	0.132			
A3	Aggregate C	Abs: 5	1.70	100.00	0.943	3.70	0.035			
Total Aggregates:				500.00	11.626	18.52	0.431			
Water										
W1	Water for CM Hydration (W1a + W1b)			300.00	4.808	11.11	0.178			
	W1a. Water from Admixtures		1.00	52.80		1.96				
	W1b. Additional Water			247.20		9.16				
W2	Water for Aggregates, SSD		1.00	61.00		2.26				
Total Water (W1 + W2):				361.00	4.808	13.37	0.18			
Solids Content of Latex Admixtures and Dyes										
S1	Latex		1.10	66.00	0.966	2.44	0.036			
S2	Liquid Dye		1.50	6.25	0.067	0.23	0.002			
Total Solids of Admixtures:				72.25	1.03	2.68	0.04			
Admixtures (including Pigments in Liquid Form)				% Solids	Dosage (fl oz/cwt)	Water in Admixture (lb/yd ³)	Amount (fl oz)	Water in Admixture (lb)	Dosage (fl oz/cwt)	Water in Admixture (lb/yd ³)
Ad1	Latex	8.8 lb/gal	60.00	200.00	44.000	59.26	1.630			
Ad2	Liquid Dye	10.0 lb/gal	50.00	20.00	6.250	5.93	0.231			
Ad3	HRWR	8.5 lb/gal	40.00	8.00	2.550	2.37	0.094			
Water from Admixtures (W1a):					52.80		1.96			
Cement-Cementitious Materials Ratio					0.450		0.450			
Water-Cementitious Materials Ratio					0.375		0.375			
Slump, Slump Flow, in.					4 +/1 in.		2.50			
M	Mass of Concrete, lbs				1740.25		64.45			
V	Absolute Volume of Concrete, ft ³				22.128		0.820			
T	Theoretical Density, lb/ft ³ = (M/V)				78.64		78.64			
D	Design Density, lb/ft ³ = (M/27)				64.45					
D	Measured Density, lb/ft ³						65.600			
A	Air Content, % = [(T - D) / T x 100%]				18.04		16.59			
Y	Yield, ft ³ = (M/D)				27		0.983			
Ry	Relative Yield = (Y/Y _D)						0.983			

The last portion of this exercise is to take the information obtained during the batching process and to go back to the design proportions (Non –SSD) and adjust them. The end result will be the Yielded Proportions.

Yielded Proportions

Adjust the “As Designed” proportions so that when all is said and done they will result in a concrete with the unit weight and air content obtained during the batching process. This is simply done by dividing the “As Designed” proportions by the value of the relative yield.

Example – Based on an “As Designed” proportion of 360 lbs of portland cement and a relative yield of 0.983, what is the “Yielded Proportion” of portland cement for the example mixture?

Solution:

$$\begin{aligned} \text{Yielded}_{\text{cement}} &= \text{Design}_{\text{cement}} / R_y \\ &= 360 \text{ pcy} / (0.983) = 368.40 \text{ pcy} \end{aligned}$$

This adjustment is then applied to all of the constituents used in the concrete mixture

Final Values and Calculations

The density, air content and slump of the yielded proportions should match those in the actual batched proportions (we are adjusting the values of the design proportions so that they match up with the batched proportions). The c/cm and w/cm ratios will stay the same (in this example). The yield must be 27 ft³ when done.

Checks

Mass of concrete = 1771.2 lbs
Volume of yielded constituents = 22.522 cf

Density of concrete = 1771.2 lbs / 27 cf = 65.6 pcf (check)
Theo. Density of concrete = 1771.2 lbs / 22.522 cf = 78.64 pcf (check)

Air content = [(27 – 22.522) / 27] x 100 = 16.59% (check)

Yield = mass/density = 1771.20/65.6 = 27 cf (check)

ONCE THE TABLE IS COMPLETE, CHECK THE YIELDED VALUES VERSUS THE SPECIFICATIONS AS OUTLINED IN THE RULES AND REGULATIONS TO DETERMINE OVERALL COMPLIANCE.

Notes:

1. The values provided in these tables are shown for MATHEMATICAL purposes only.
2. Teams should not consider the mixture proportions shown will actually result in a concrete with the needed fresh (slump, air content) and hardened (strength) characteristics needed for the competition.
3. Values such as specific gravity are based on generalized numbers and should not be used for your design calculations (i.e., do not reference this document for which you based your values on).
4. Some numbers shown may be off (second and third decimal place) due to the use of Excel spreadsheet (rounding).

Mixture ID:				Design Proportions (Non SSD)		Actual Batched Proportions		Yielded Proportions	
Y _D	Design Batch Size (ft ³):		1						
Cementitious Materials			SG	Amount (lb/yd ³)	Volume (ft ³)	Amount (lb)	Volume (ft ³)	Amount (lb/yd ³)	Volume (ft ³)
CM1	Portland Cement		3.15	360.00	1.832	13.33	0.068	366.40	1.864
CM2	Class C Fly Ash		2.55	340.00	2.137	12.59	0.079	346.05	2.175
CM3	Blast Furnace Slag		2.69	100.00	0.596	3.70	0.022	101.78	0.606
Total Cementitious Materials:				800.00	4.564	29.63	0.17	814.23	4.65
Fibers									
F1	PVA Fibers		1.10	5.00	0.073	0.19	0.003	5.09	0.074
F2	Nylon Fiber		1.30	2.00	0.025	0.07	0.001	2.04	0.025
Total Fibers:				7.00	0.097	0.259	0.004	7.124	0.099
Aggregates									
A1	Aggregate A	Abs: 20	0.45	200.00	7.123	7.41	0.264	203.56	7.249
A2	Aggregate B	Abs: 8	0.90	200.00	3.561	7.41	0.132	203.56	3.625
A3	Aggregate C	Abs: 5	1.70	100.00	0.943	3.70	0.035	101.78	0.959
Total Aggregates:				500.00	11.626	18.52	0.431	508.89	11.833
Water									
W1	Water for CM Hydration (W1a + W1b)			300.00	4.808	11.11	0.178	305.34	4.893
	W1a. Water from Admixtures		1.00	52.80		1.96		53.74	
	W1b. Additional Water			247.20		9.16		251.60	
W2	Water for Aggregates, SSD		1.00	61.00		2.26		62.08	
Total Water (W1 + W2):				361.00	4.808	13.37	0.18	367.42	4.893
Solids Content of Latex Admixtures and Dyes									
S1	Latex		1.10	66.00	0.966	2.44	0.036	67.17	0.983
S2	Liquid Dye		1.50	6.25	0.067	0.23	0.002	6.36	0.068
Total Solids of Admixtures:				72.25	1.03	2.68	0.04	73.53	1.05
Admixtures (including Pigments in Liquid Form)									
			% Solids	Dosage (fl oz/cwt)	Water in Admixture (lb/yd ³)	Amount (fl oz)	Water in Admixture (lb)	Dosage (fl oz/cwt)	Water in Admixture (lb/yd ³)
Ad1	Latex	8.8 lb/gal	60.00	200.00	44.000	59.26	1.630	203.6	44.78
Ad2	Liquid Dye	10.0 lb/gal	50.00	20.00	6.250	5.93	0.231	20.4	6.36
Ad3	HRWR	8.5 lb/gal	40.00	8.00	2.550	2.37	0.094	8.1	2.60
Water from Admixtures (W1a):					52.80		1.96		53.74
Cement-Cementitious Materials Ratio				0.450		0.450		0.450	
Water-Cementitious Materials Ratio				0.375		0.375		0.375	
Slump, Slump Flow, in.				4 +/1 in.		2.50		2.50	
M	Mass of Concrete, lbs			1740.25		64.45		1771.20	
V	Absolute Volume of Concrete, ft ³			22.128		0.820		22.522	
T	Theoretical Density, lb/ft ³ = (M/V)			78.64		78.64		78.64	
D	Design Density, lb/ft ³ = (M/27)			64.45					
D	Measured Density, lb/ft ³					65.600		65.600	
A	Air Content, % = [(T - D) / T x 100%]			18.04		16.59		16.59	
Y	Yield, ft ³ = (M/D)			27		0.983		27	
Ry	Relative Yield = (Y/Y _D)					0.983			

Formatting of Electronic Deliverables *(Applicable Only to ASCE National Concrete Canoe Competition™)*

General Comments

- National competitors are required to submit electronic copies of their Design Paper and Engineer's Notebook. This requirement is not applicable to the Conference Competitions
- All electronic deliverables shall be in Adobe Acrobat® PDF format and copied to one (1) compact disc (CD). Pictures shall be provided as one PDF file.
- The following three (3) figures detail the overall formatting. Additional details are provided as necessary.

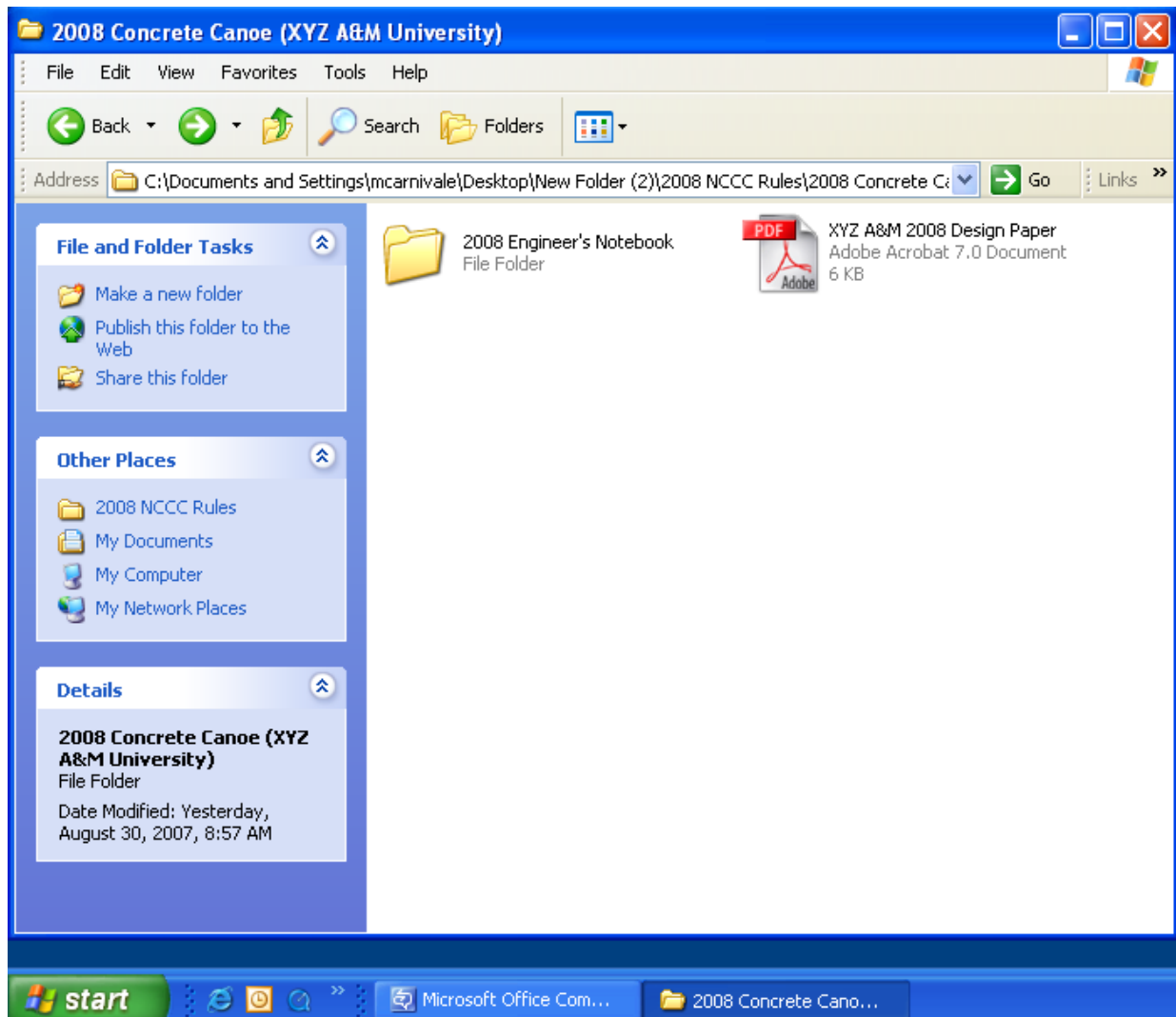

Figure 1 – Required Electronic Deliverables (Design Paper and Engineer's Notebook)

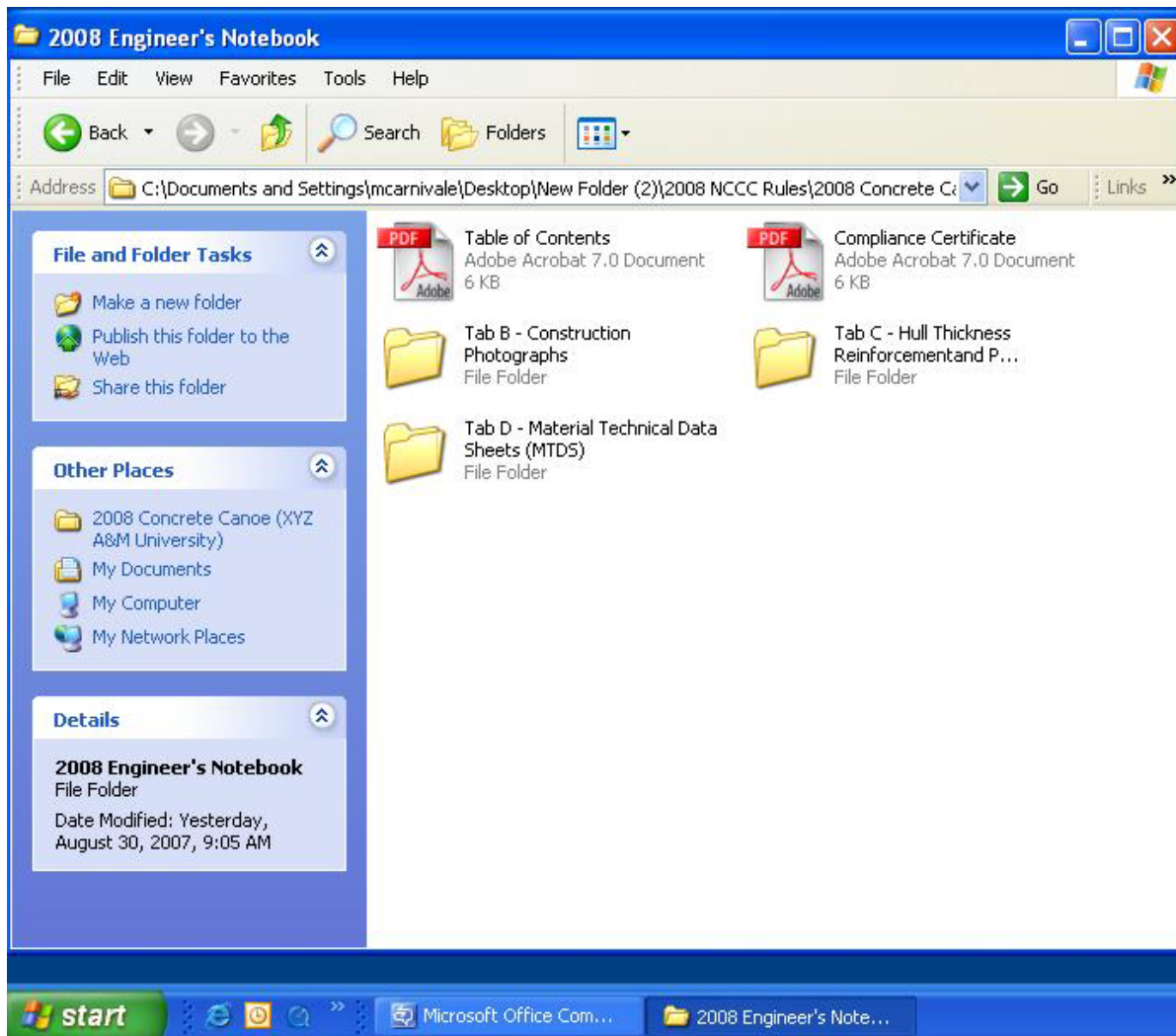

Figure 2 – Contents of Engineer’s Notebook

Notes

- The Engineer’s Notebook shall be broken down into the following categories:
 - Table of Contents (*PDF*)
 - Tab A – Compliance Certificate (*PDF*)
 - Tab B – Construction Photographs (*PDF*)
 - Tab C – Hull Thickness/Reinforcement and Percent Open Area Calculations (*folder*)
 - Tab D – Material Technical Data Sheets (MTDS) (*folder*)

- Within each respective folder there shall be complete PDF files which contain the information as outlined in the rules and regulations.

- Figure 3 provides an example of such a folder [Material Technical Data Sheets (MTDS)].

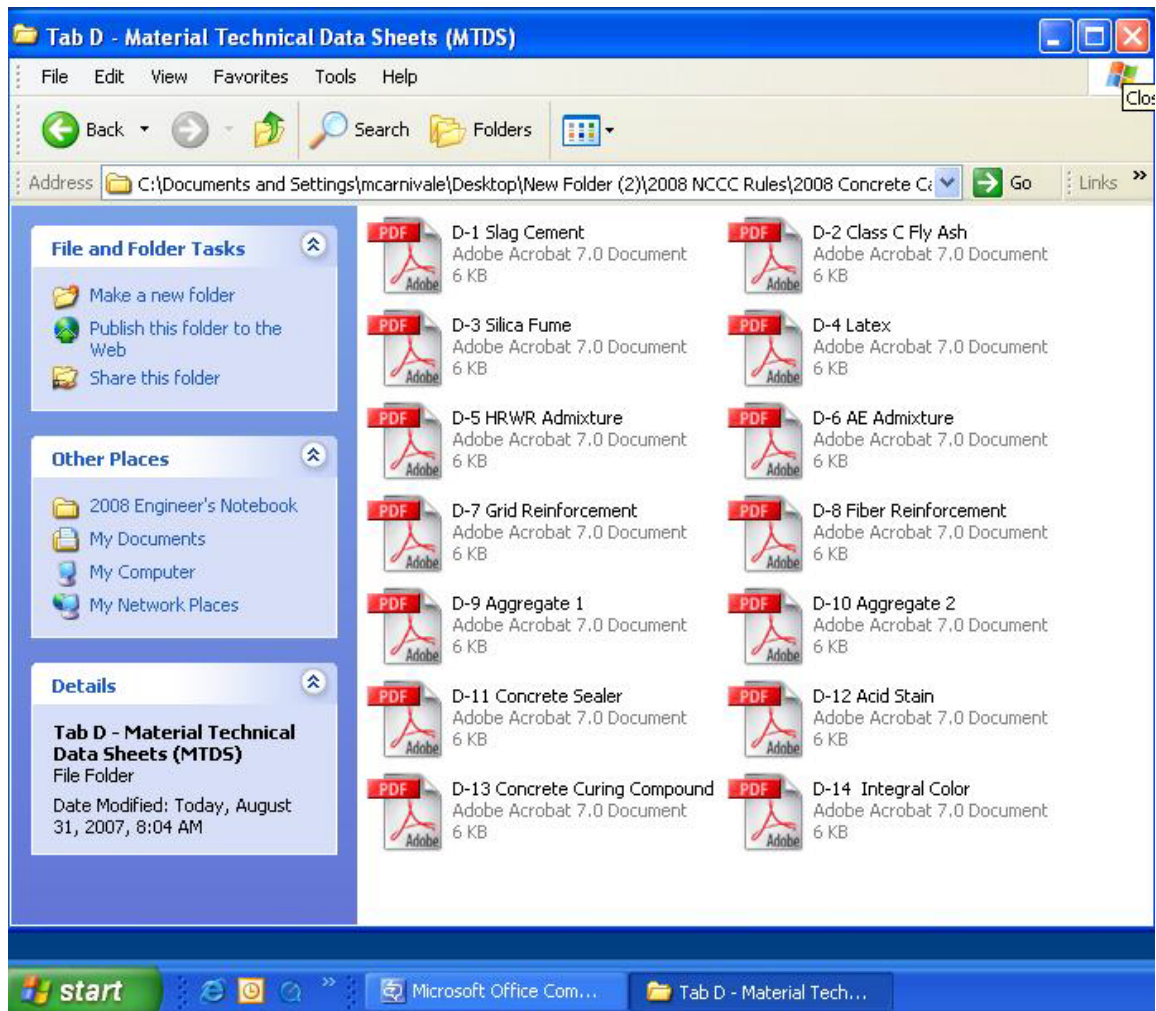

Figure 3 – Contents of Example Folder (Tab D – MTDS)

- This example only shows how to format the information required and does not include all possible files for the materials used. Such a list will vary from team to team. For brevity, the contents of the other folders are not shown. The following is a list of PDF files which are applicable to the folders:
 - Tab B – Construction Photographs
 - Mold Construction – Six (6) photographs
 - Canoe Construction – Six (6) photographs
 - Finishing Techniques – Four (4) photographs
 - Tab C – Hull Thickness and Reinforcement Calculations
 - Reinforcement Thickness and Hull-to-Reinforcement Thickness Calculations
 - Percent Open Area (POA) Calculations
 - *Note:* Reinforcement sample are required in the hard copy of the notebook. There is no requirement to provide a “sample” (like a photograph) for the electronic version.
- *Note:* Material Safety Data Sheets (MSDS) are not technical data sheets.